

LYFT

PULSED EDDY CURRENT (PEC) PROBES

PROBES CATALOG



PULSED EDDY CURRENT ARRAY (PECA) PROBES
SINGLE ELEMENT PEC PROBES
SHIP DECK INSPECTION KITS
UNDERWATER PEC PROBES
SPLASH ZONE PEC PROBES
GALVANIZED STEEL CLADDING PROBES
TANK FLOOR PEC PROBES

TABLE OF CONTENTS

3	We are Eddyfi Technologies
4	Probe Numbering
5	Pulsed Eddy Current Array (PECA) Probes
9	Single Element PEC Probes
11	Ship Deck Inspection Kit
13	Underwater & Splash Zone PEC Probes
16	PEC Probe for Galvanized Steel Cladding
17	Tank Floor PEC Probes
18	Accessories



ELEVATING INDUSTRY STANDARDS WITH EDDYFI TECHNOLOGIES

Non-destructive testing (NDT) of critical components is a vital part of asset integrity management and safety in many industries such as the oil & gas and power generation industries. Corrosion under insulation (CUI) is one of the chemical processing industry's worst problems, the cost associated to mitigating it astronomical.

WE ARE EDDYFI TECHNOLOGIES

To offer a truly powerful and modern solution to address the CUI challenge, Eddyfi Technologies has spared no effort to develop Eddyfi® Lyft®, which completely reinvents pulsed eddy current (PEC) technology. The patent-pending solution features a state-of-the-art portable instrument with real-time C-scan imaging, fast data acquisition, as well as grid-mapping and dynamic scanning modes. The solution is designed to scan metals as thick as 100 mm (4 in), non-conductive insulation up to 300 mm (12 in) thick through aluminum, stainless steel and galvanized steel weather jackets, and supports pulsed eddy current array (PECA™).

Lyft is packed with automation and advanced algorithms that remove operator-specific dependence. Thanks to the power of SmartPULSE™ technology, pulser and receiver parameters (gain, duration, time gates, filters, etc.) are automatically optimized. It also optimizes wall thickness measurements, which ensures optimal performance and repeatability.

Eddyfi Technologies is dedicated to PEC. This is why we want to offer the best selection of probes to match all your application needs.

Eddyfi Technologies is headquartered in beautiful Québec, Canada, at the heart of the city's advanced NDT cluster. We are the most dynamic company in the field of advanced NDT equipment—we've made it our mission to push the limits of electromagnetic testing to new heights, which we're proving again with Lyft and its line of probes.

If, for some reason, the probes herein do not fit your specific needs, we are equipped to develop custom solutions capable of tackling the most challenging applications.

For more, visit eddyfi.com or contact us at probes@eddyfi.com.



PROBE NUMBERING

Probe numbers are located on the probe cable, near its Fischer connector.

Technology

- **PEC:** Single-element pulsed eddy current
- **PECA:** Pulsed eddy current array

Model Size

- **025:** PEC small
- **089:** PEC medium
- **152:** PEC large
- **SM:** PECA small
- **MED:** PECA medium

Model (application specific)

- **HR:** High-resolution
- **GS:** Galvanized steel
- **SZ:** Splash zone
- **TF:** Tank floor
- **UW:** Underwater
- **SF:** Ship floor

Channels

- **xCH:** Number of PECA elements=

Cable Type

- **H:** Heavy-duty poly
- **HT:** High-temperature poly
- **U:** Underwater cable

Cable Length

- Indicates the length of the cable in metres.

Cable Exit Position

- **S:** Side exit
- **B:** Back exit
- **T:** Top exit

PEC - 152 - ENC - G2 - H05S
Technology Model size Encoder Generation Cable type Cable exit position
Cable length

PEC - SZ - 089 - G2 - H20S
Technology Model Model size Generation Cable type Cable exit position
Cable length

PECA - 6CH - MED - H05S
Technology Channels Model size Cable type Cable exit position
Cable length

PULSED EDDY CURRENT ARRAY (PECA) PROBES

The PECA probes are specifically engineered for high productivity inspections in grid, or high-resolution dynamic modes. The wide coverage not only makes inspections faster than ever, but also improves data quality and minimizes inspection preparation with Eddyfi Grid-As-U-Go.

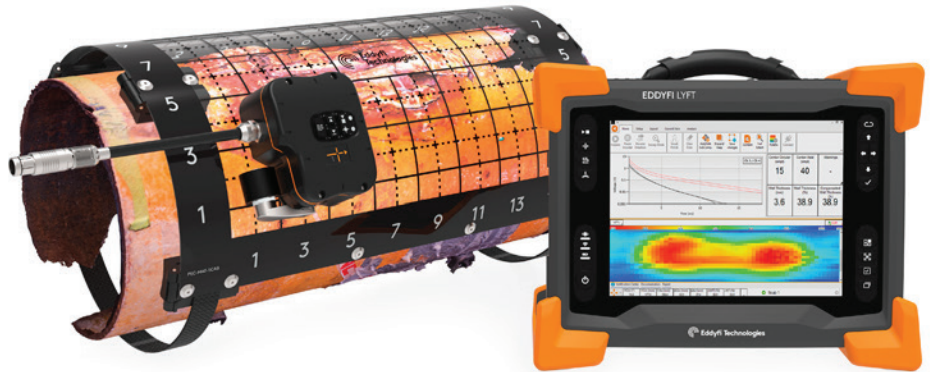

SELECTING THE RIGHT PECA PROBE

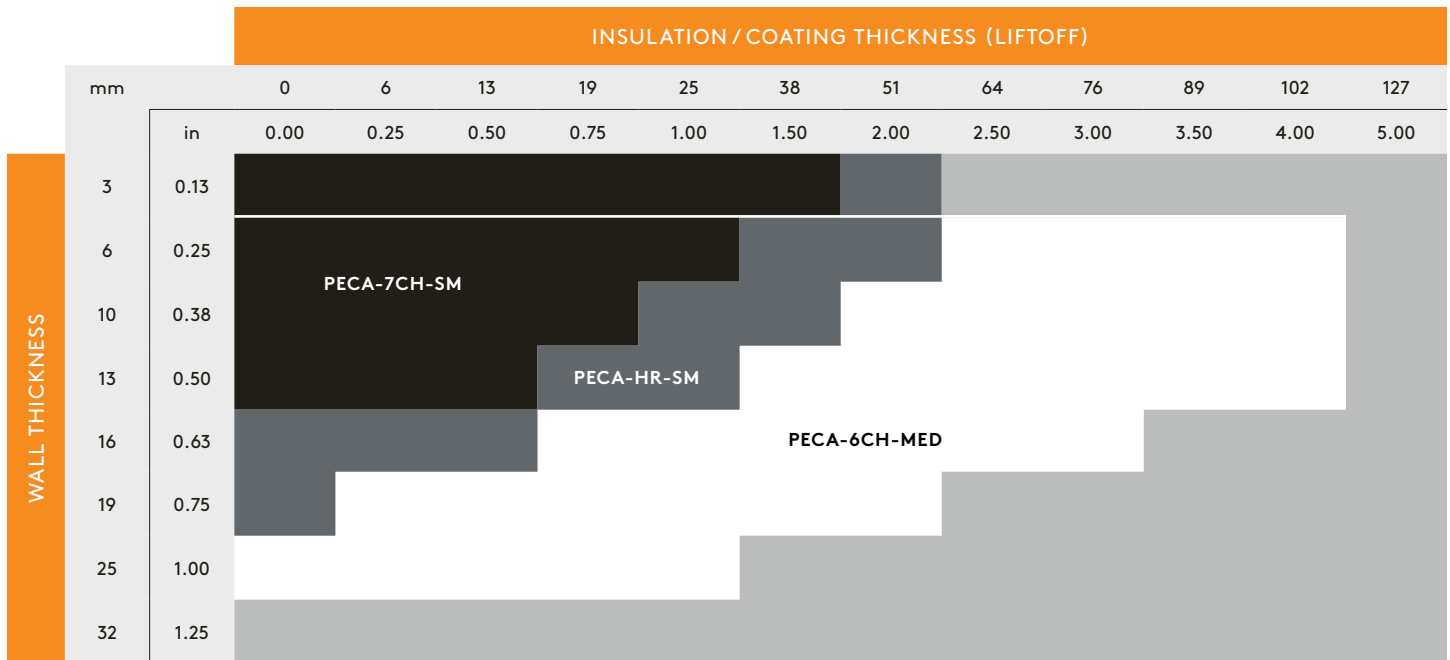

- Note 1: PECA-HR-SM is a dedicated probe used for scab inspections.
- Note 2: Estimated scab height should be considered as liftoff when validating the application range for the PECA-HR-SM probe.
- Note 3: Smallest configuration for PECA-6CH-MED probe: 102 mm (4 in) OD pipe, schedule 40, with 25 mm (1 in) insulation; total OD 152 mm (6 in).
- Note 4: PECA-7CH-SM-H05S is an application specific probe for ship deck inspection.

PECA-HR-SM-H05S

Casing	Small
Number of channels	3 dual sensors (6 total)
Total coverage	75mm (3in)
Wall thickness	3-19mm (0.12-0.75in)
Footprint zero liftoff	22mm (0.87in)
Liftoff	Up to 50mm (2in)
Encoder	PEC-ENC-STD
Weather jacket	Not supported
Hardware compatibility	Compatible with LYFT-PEC-GDA
Minimal software requirements	Lyft-Go 2.2

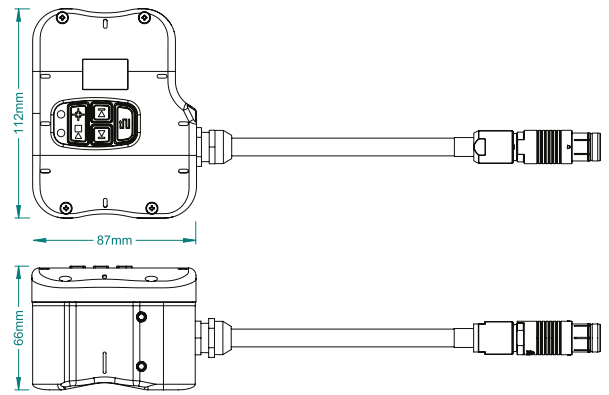

GRID-AS-YOU-GO™

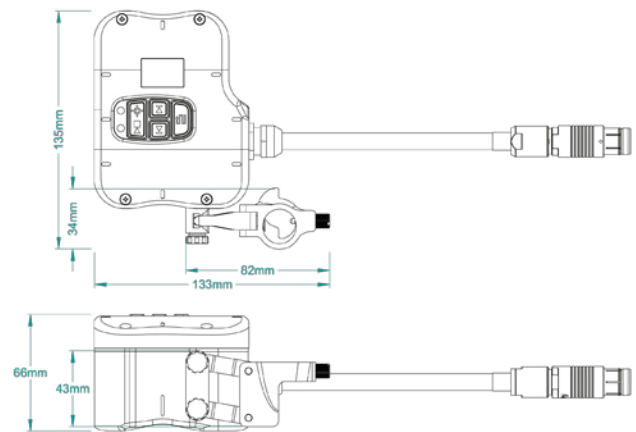
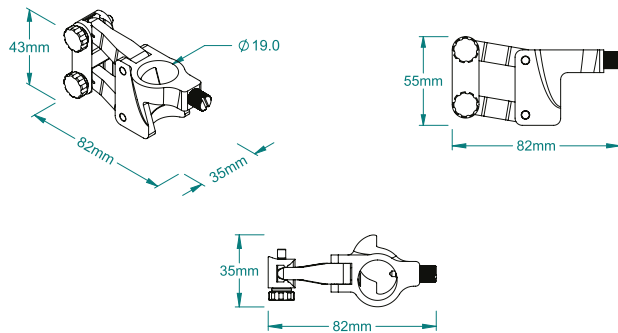

PECA-HR-MAT

Liftoff	12.7 mm (0.5 in) 25.4 mm (1 in)
Strap length	On mat Ø 304.8 mm (12 in) Length 1371.6 mm (54 in)
	Optional removable Ø 609.6 mm (24 in) Length 1143 mm (45 in)

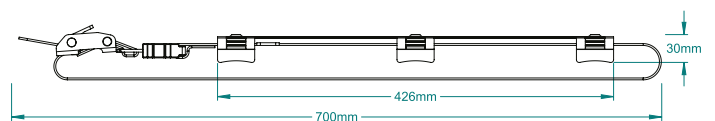
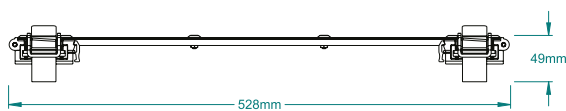
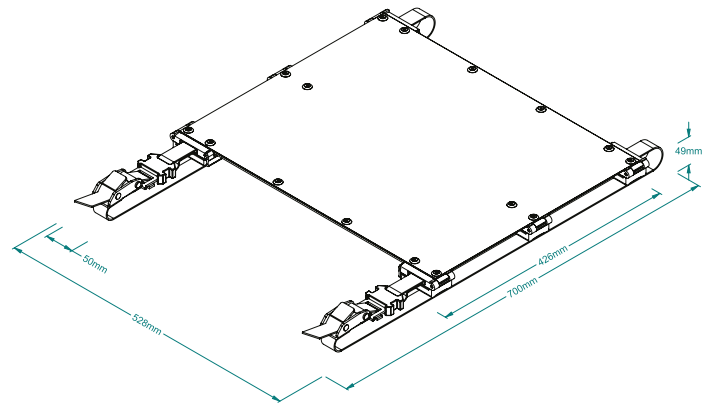

PECA-6CH-MED-H05S

Casing	Medium
Number of channels	6
Total coverage	457mm (18in)
Wall thickness	6-25mm (0.25-1.00in)
Footprint zero liftoff	46mm (1.80in)
Liftoff	Up to 102mm (4in)
Encoder	PECA-MED-ENC
Weather jacket	Stainless steel up to 1.5 mm (0.06 in) Aluminum up to 1.0 mm (0.04 in)
Hardware compatibility	Compatible with LYFT-PEC-GDA
Minimal software requirements	Lyft-Go 2.0

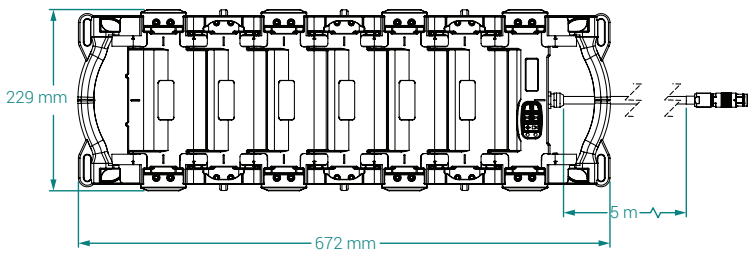
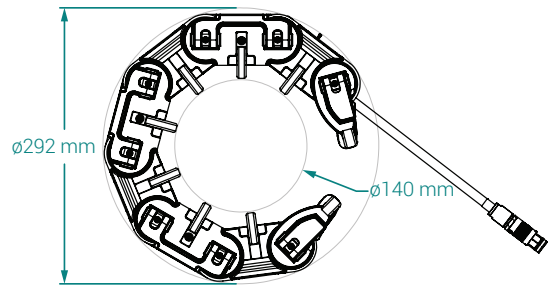

GRID-AS-YOU-GO

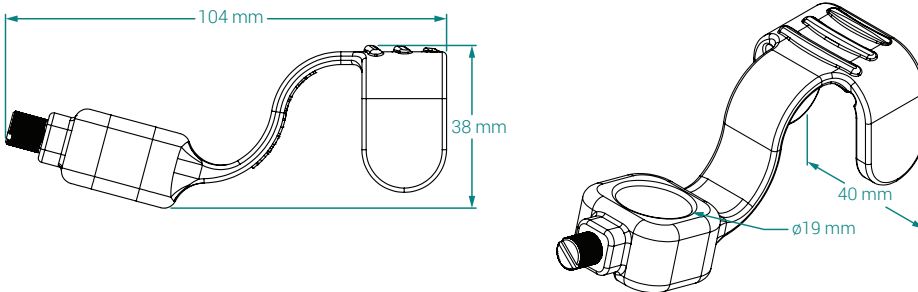

CARRIAGE, CLIP-ON HANDLES

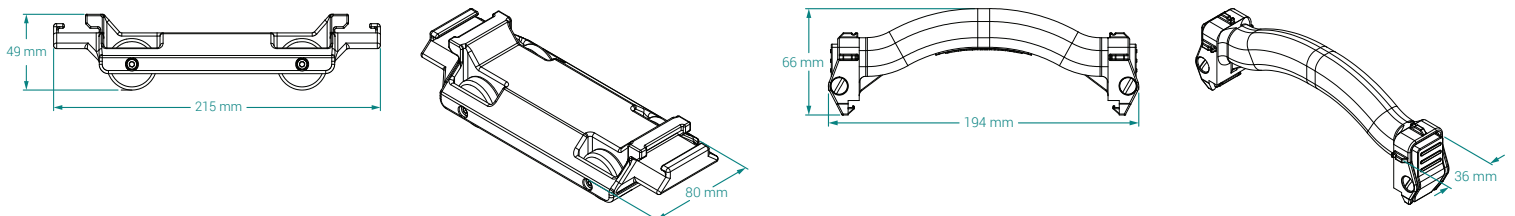

STRAPS

MODEL	LENGTH
Short	720 mm (28 in)
Medium	1240 mm (49 in)
Long	1920 mm (76 in)

STRAP CONFIGURATION	MAXIMUM OD
Medium	483 mm (19 in)
Short + Medium	660 mm (26 in)
Medium + Long	1067 mm (42 in)
Short + Medium + Long	1245 mm (49 in)

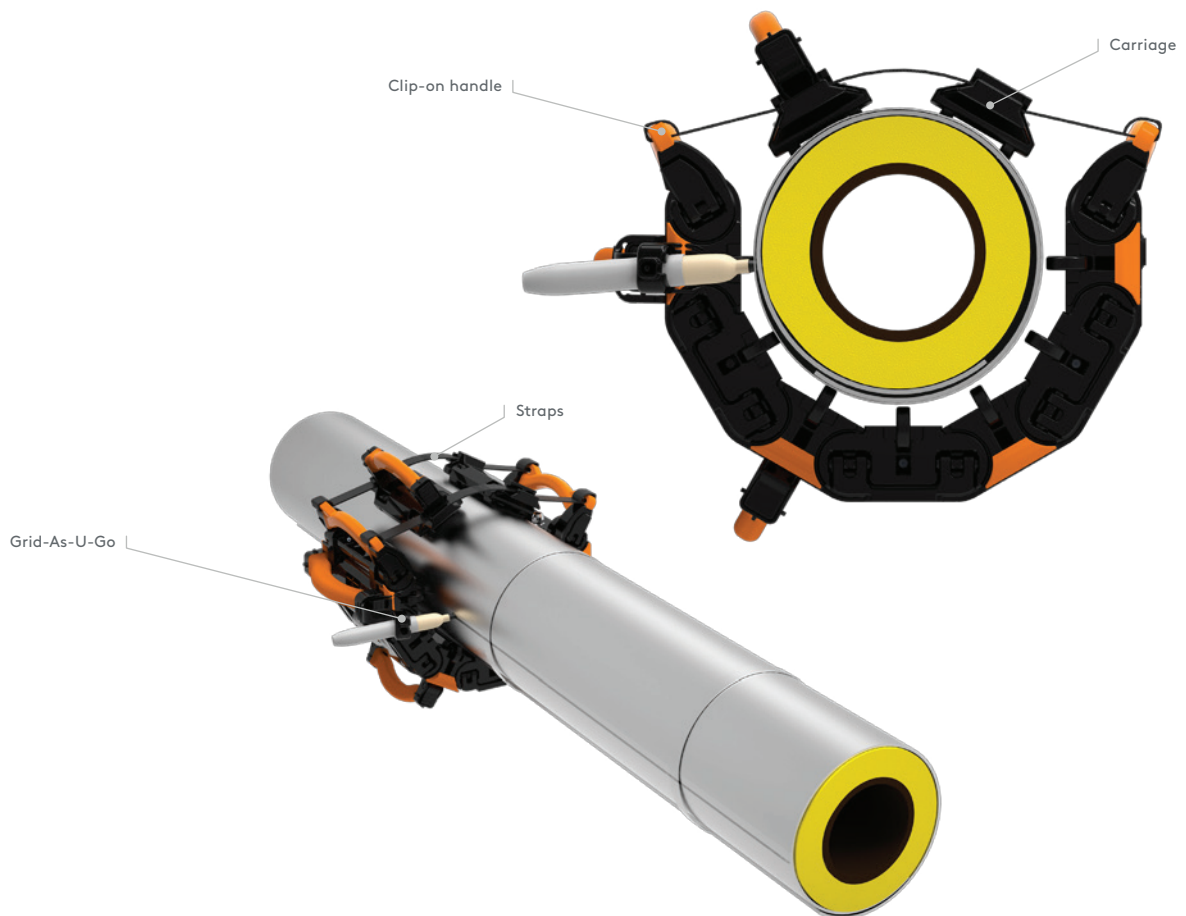

SINGLE ELEMENT PEC PROBES

Single-element PEC probes are designed to detect CUI, CUF, and FAC in pipes, vessels, sphere legs, small pipes and in limited access areas. They are available in three different sizes for the right balance between wall thickness and liftoff. They offer enough flexibility to support metals as thick as 100 mm (4 in), insulation up to 300 mm (12 in) thick (fiber glass, plastic wrap, concrete, and any non-ferrous material), as well as stainless steel, aluminum, or galvanized steel weather jackets.



SELECTING THE RIGHT SINGLE-ELEMENT PEC PROBE

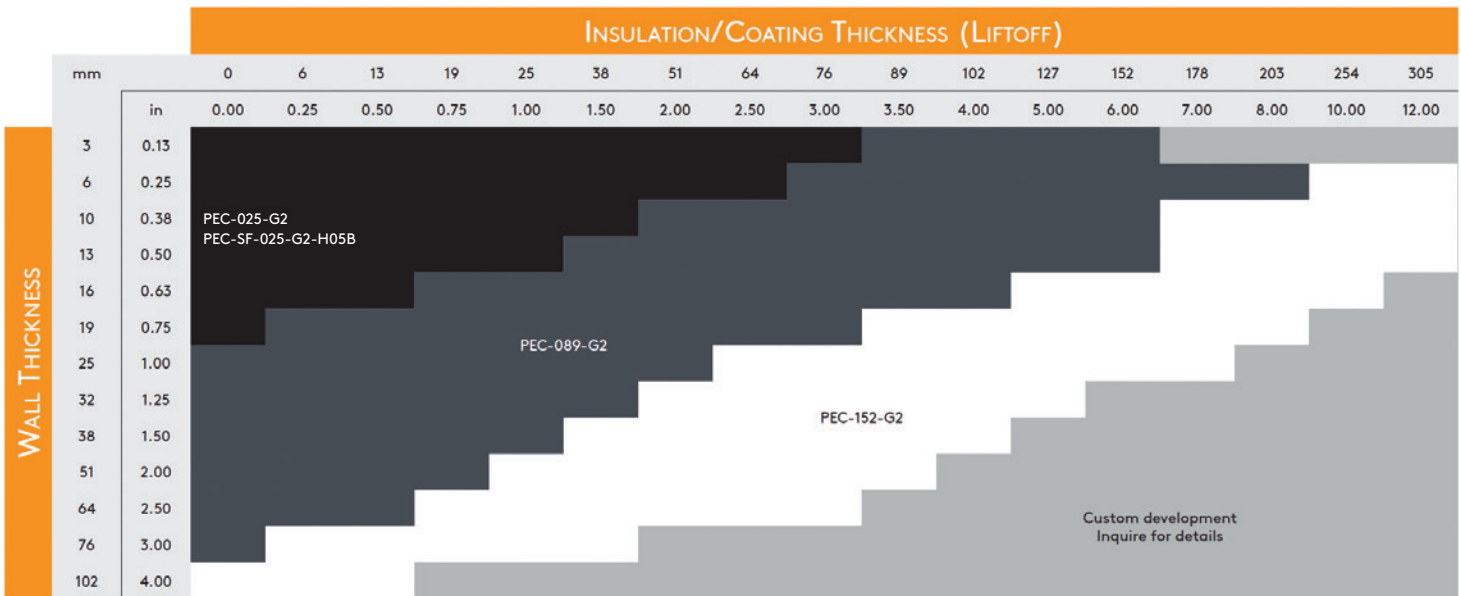

Note 1: PEC-SF-025-G2-H05B is an application specific probe for ship deck inspection. Details are provided in the later section about the "Ship deck inspection kit".

Note 2: We recommend using the PEC-GS-089-G2 in applications on galvanized steel (GS) weather jackets. If you use other standard probes over GS weather jackets, add 40 mm (1.5 in) liftoff for every 0.5 mm (0.020 in) of GS.

PEC-025-G2-H05S

Casing	Small
Number of channels	1 channel (Single-element)
Wall thickness	3-19mm (0.12-0.75in)
Footprint zero liftoff	35mm (1.38in)
Liftoff	Up to 76mm (3in)
Encoder	PEC-ENC-STD
Weather jacket	Stainless steel up to 1.5 mm (0.06 in) Aluminum up to 1.0 mm (0.04 in) Galvan. steel up to 1.0 mm (0.04 in)
Hardware compatibility	Compatible with all models
Minimal software requirements	Lyft-Go 1.2+

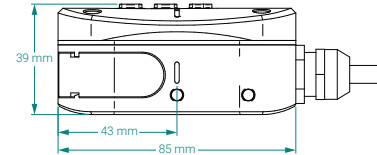
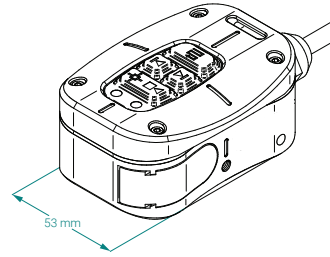

PEC-089-G2-H05S

Casing	Medium
Number of channels	1 channel (Single-element)
Wall thickness	3-76mm (0.12-3.00in)
Footprint zero liftoff	62mm (2.44in)
Liftoff	Up to 203mm (8in)
Encoder	PEC-ENC-STD
Weather jacket	Stainless steel up to 1.5 mm (0.06 in) Aluminum up to 1.0 mm (0.04 in) Galvan. steel up to 1.0 mm (0.04 in)
Hardware compatibility	Compatible with all models
Minimal software requirements	Lyft-Go 1.2+

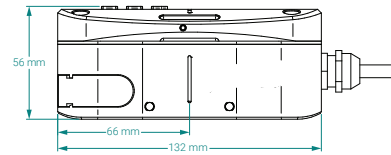
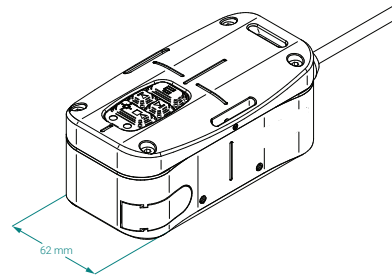

PEC-152-G2-H05S

Casing	Large
Number of channels	1 channel (Single-element)
Wall thickness	6-102mm (0.25-4.00in)
Footprint zero liftoff	100mm (3.94in)
Liftoff	Up to 305mm (12in)
Encoder	PEC-ENC-STD
Weather jacket	Stainless steel up to 1.5 mm (0.06 in) Aluminum up to 1.0 mm (0.04 in) Galvan. steel up to 1.0 mm (0.04 in)
Hardware compatibility	Compatible with all models
Minimal software requirements	Lyft-Go 1.2+

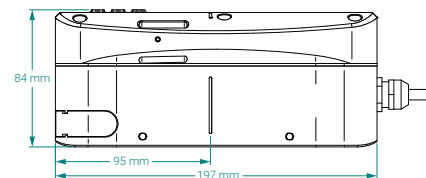
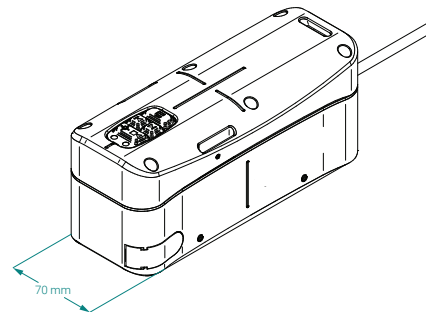

SHIP DECK INSPECTION KIT

The ship deck inspection kit includes an Array probe and a single element PEC probe, each designed for this application. The Array probe provides fast and high-resolution scanning of ship decks, while the single element probe grants access to restricted areas. The kit is equipped for efficient deployment on ships, with options for stand-up operating positions using the pole or direct probe handling with the clip-on handle.



PECA-7CH-SM-H05S

Casing	Small array
Number of channels	7 Channels
Total coverage	178mm (7in)
Wall thickness	3-13mm (0.125-0.5in)
Footprint zero liftoff	17mm (0.67in)
Liftoff	Up to 38mm (1.5in)
Encoder	PEC-ENC-STD
Weather jacket	Not supported
Hardware compatibility	Compatible with LYFT-PEC-GDA
Minimal software requirements	Lyft-Go 2.5

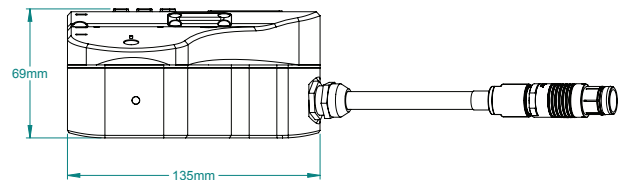
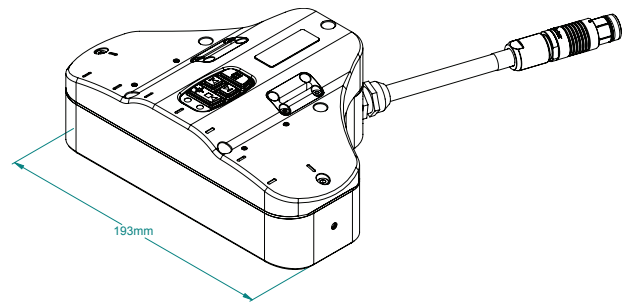

PEC-SF-025-G2-H05B

Casing	Medium
Number of channels	1 channel (Single-element)
Wall thickness	3-19mm (0.12-0.75in)
Footprint zero liftoff	35mm (1.38in)
Liftoff	Up to 76mm (3in)
Encoder	PEC-ENC-STD
Weather jacket	Stainless steel up to 1.5 mm (0.06 in) Aluminum up to 1.0 mm (0.04 in) Galvan. steel up to 1.0 mm (0.04 in)
Hardware compatibility	Compatible with all models
Minimal software requirements	Lyft-Go 2.5+

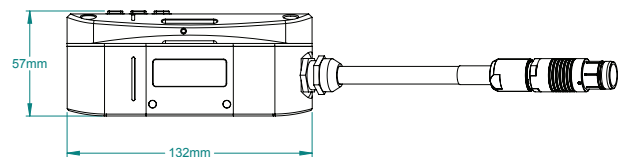
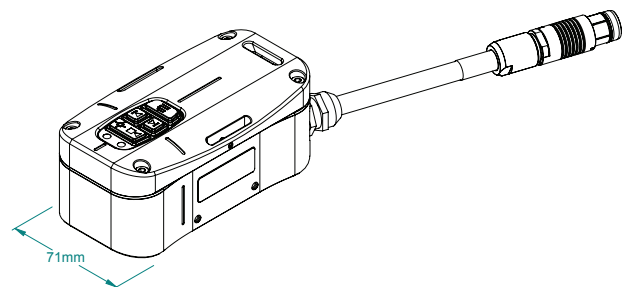

PEC-089-HANDLE

See details in the accessories section

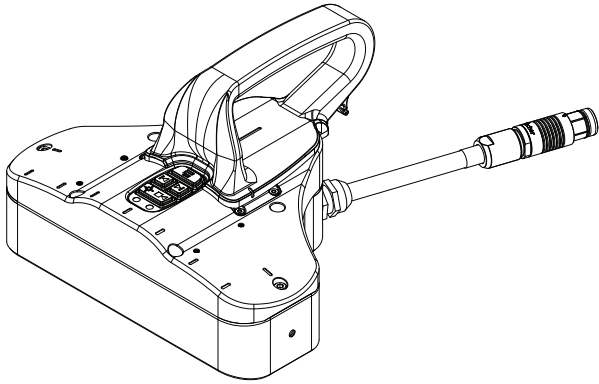

PEC-POLE-2M

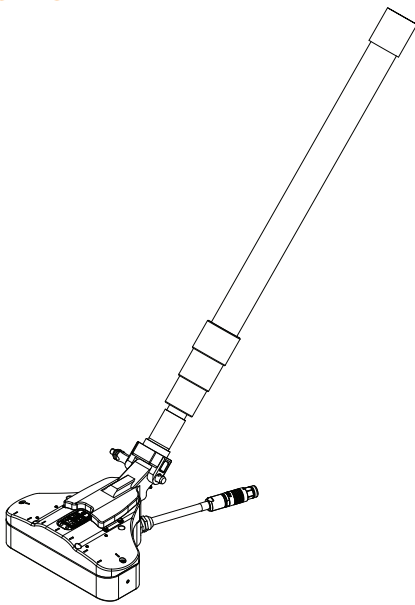

PEC-POLE-SF-2M

Maximum length	2 m (6.5ft)
Retracted length	0.7 m (2.3 ft)
Material (pole)	Carbon Fiber Reinforced Polymer (CFRP)
Material (fork and remote)	Nylon 11
Compatibility	PECA-7CH-SM-H05S, PEC-SF-025-G2-H05B, PEC-089-G2-H05S
Total weight	0.8 kg (1.8 lb)



UNDERWATER & SPLASH ZONE PEC PROBES

Underwater PEC probes are specifically designed to detect corrosion hidden under marine growth and/or coatings, without surface preparation, in offshore applications such as risers, jetty piles, caissons, underwater piping systems, and conductor inspections.



SELECTING THE RIGHT UNDERWATER OR SPLASH ZONE PEC PROBE

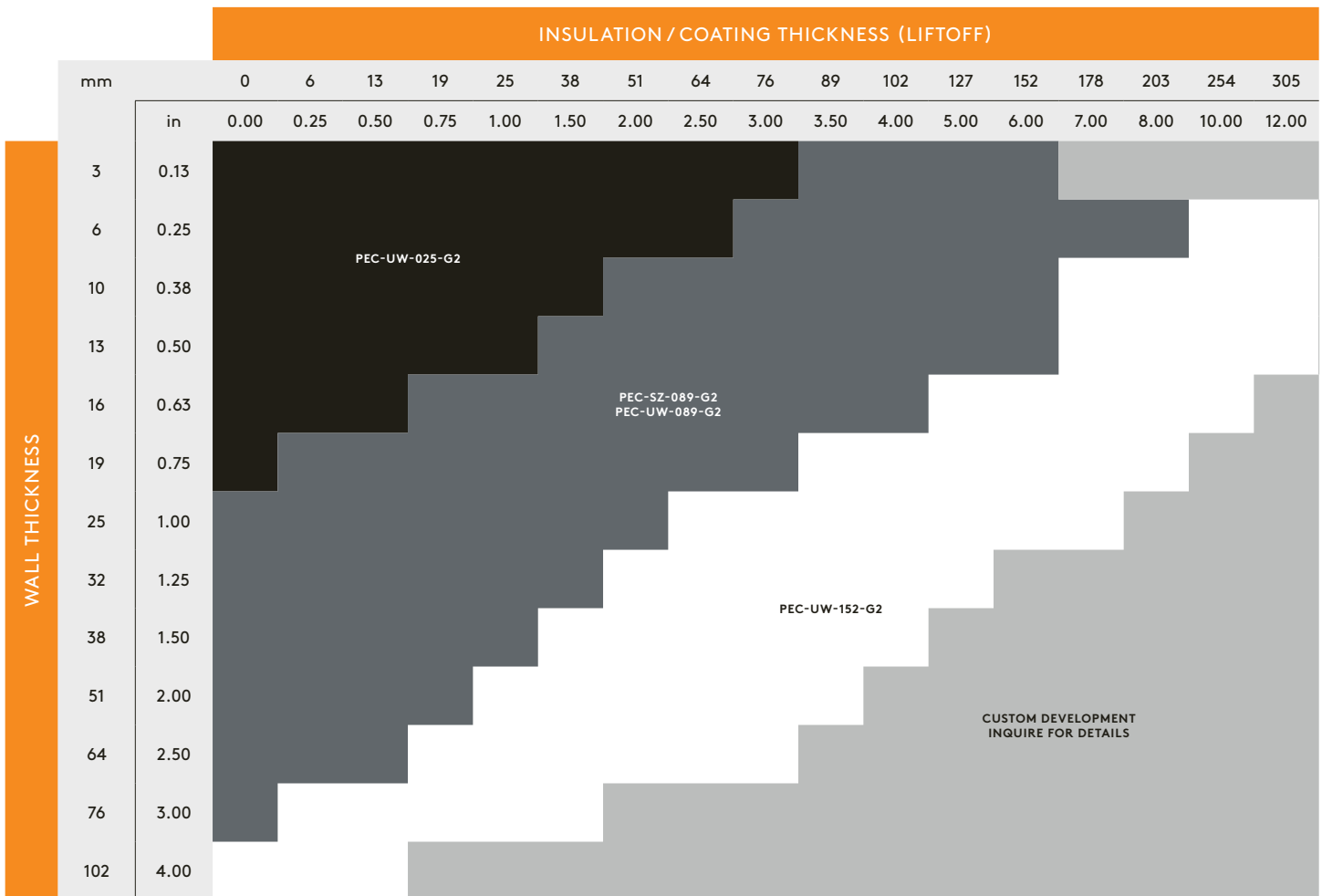

PEC-SZ-089-G2-H25S

Casing	Medium
Number of channels	1 channel (Single-element)
Wall thickness	3-76mm (0.12-3.00in)
Footprint zero liftoff	62mm (2.44in)
Liftoff	Up to 203mm (8in)
Encoder	None
Cable	Heavy duty Standard Black 25m (82ft)
Ingress protection / water resistance	Watertight down to 15 m (49ft) (1.5 ATM)
Hardware compatibility	Compatible with all models
Minimal software requirements	Lyft-Go 1.2+

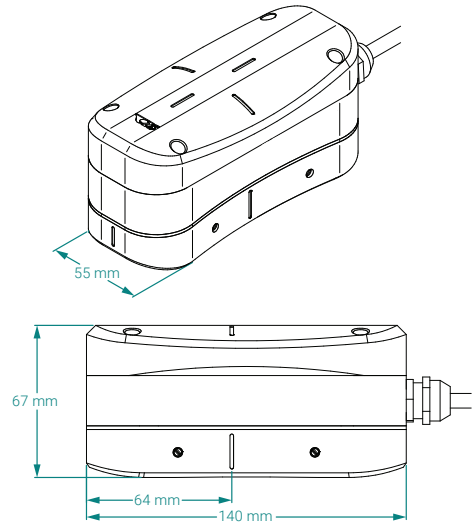

PEC-UW-025-G2-U050S/ U100S

Casing	Small
Number of channels	1 channel (Single-element)
Wall thickness	3-19mm (0.12-0.75in)
Footprint zero liftoff	35mm (1.38in)
Liftoff	Up to 76mm (3in)
Encoder	None
Cable	U050S: Underwater Neon Green 50m* U100S: Underwater Neon Green 100m* *Comes on a heavy-duty reel
Ingress protection / water resistance	Watertight down to 100 m (328ft) (10 ATM)
Hardware compatibility	Compatible with all models
Minimal software requirements	Lyft-Go 2.0

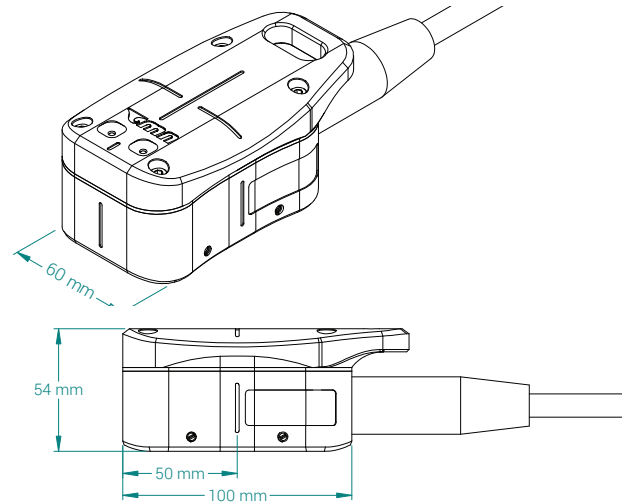

PEC-UW-089-G2-U050S/ U100S

Casing	Medium
Number of channels	1 channel (Single-element)
Wall thickness	3-76mm (0.12-3.00in)
Footprint zero liftoff	62mm (2.44in)
Liftoff	Up to 203mm (8in)
Encoder	None
Cable	U050S: Underwater Neon Green 50m* U100S: Underwater Neon Green 100m* *Comes on a heavy-duty reel
Ingress protection / water resistance	Watertight down to 100 m (328ft) (10 ATM)
Hardware compatibility	Compatible with all models
Minimal software requirements	Lyft-Go 1.3

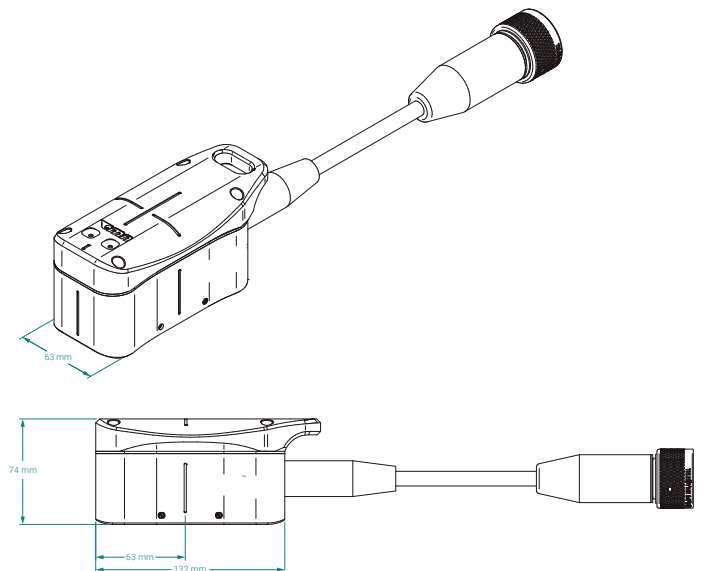

PEC-UW-152-G2-U050S/ U100S

Casing	Large
Number of channels	1 channel (Single-element)
Wall thickness	6-102mm (0.25-4.00in)
Footprint zero liftoff	100mm (3.94in)
Liftoff	Up to 305mm (12in)
Encoder	None
Cable	U050S: Underwater Neon Green 50m* U100S: Underwater Neon Green 100m* *Comes on a heavy-duty reel
Ingress protection / water resistance	Watertight down to 100 m (328ft) (10 ATM)
Hardware compatibility	Compatible with all models
Minimal software requirements	Lyft-Go 1.3

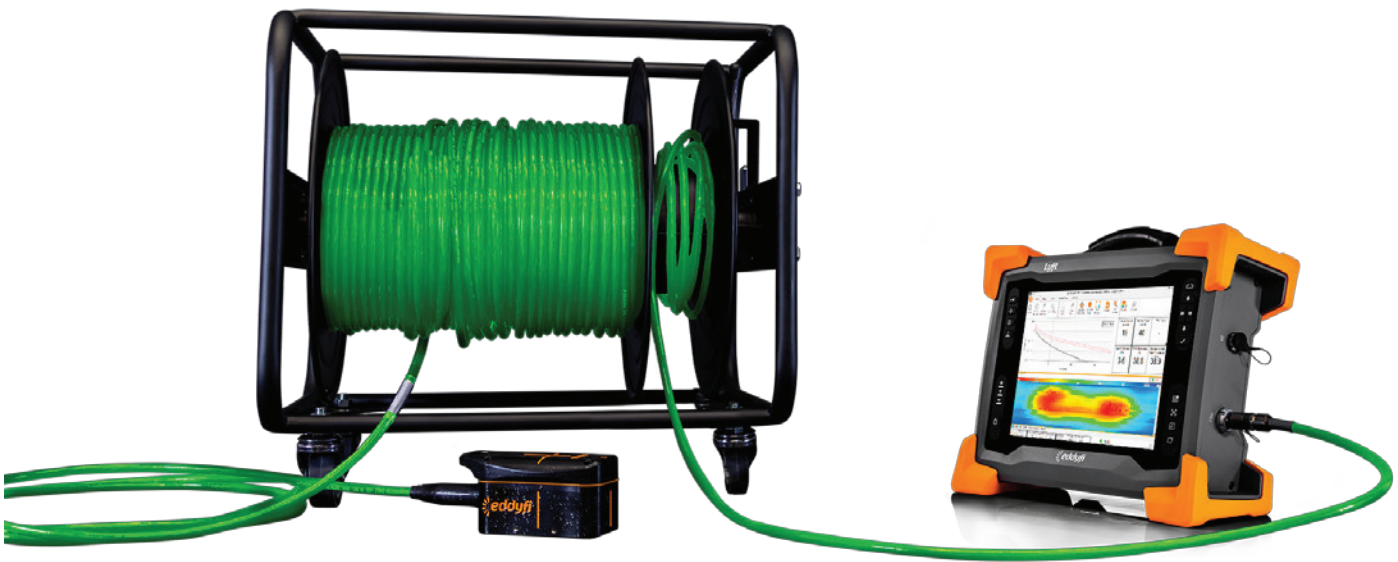
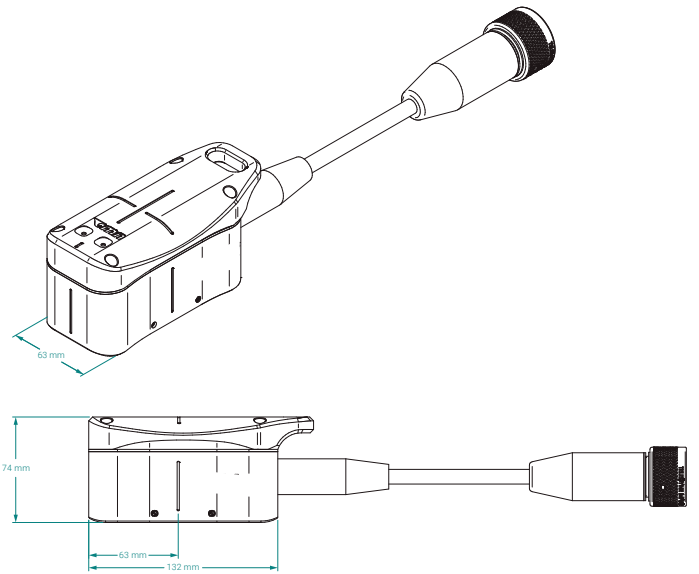

PEC PROBE FOR GALVANIZED STEEL CLADDING

The patent-pending PEC-GS probe is dedicated to inspecting insulated structures protected by galvanized steel weather jackets. Being ferromagnetic, galvanized steel cladding is a challenge for PEC inspections. Designed to overcome the adverse effects of this material, the patent-pending probe ensures improved signal penetration, excellent detection capabilities and sizing accuracy, and enhanced signal-to-noise ratio (SNR).

		INSULATION / COATING THICKNESS (LIFTOFF)										
		0	13	25	38	51	64	76	89	102	127	152
mm	in	0.00	0.50	1.00	1.50	2.00	2.50	3.00	3.50	4.00	5.00	6.00
	WALL THICKNESS	6	0.25	PEC-GS-089-G2								
10		0.38	PEC-GS-089-G2									
13		0.50	PEC-GS-089-G2									
16		0.63	PEC-GS-089-G2									
19		0.75	PEC-GS-089-G2									
25		1.00										
32		1.25										
38		1.50										

PEC-GS-089-G2-H05S

Casing	Medium
Number of channels	1 channel (Single-element)
Wall thickness	6-38mm (0.25-1.50in)
Footprint zero liftoff	62mm (2.44in)
Liftoff	13-152mm (0.5-6.0in)
Encoder	None (grid scanning mode only)
Weather jacket	Galvan. steel up to 1.0mm (0.04in)* *Not suited for corrugated cladding
Hardware compatibility	Compatible with all models
Minimal software requirements	Lyft-Go 1.3

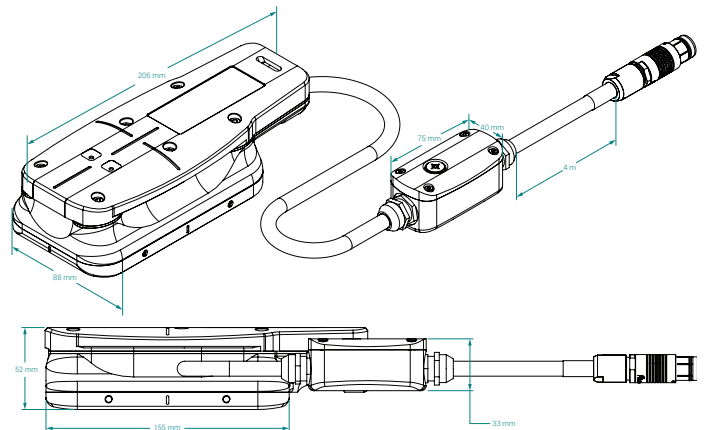

TANK FLOOR PEC PROBES

The tank floor probe enables in-service inspection of storage tank annular rings. With its super thin 4.8 mm (0.2 in) titanium blade, the probe can slide up to 400 mm (16 in) under tank floor edges, assessing the remaining wall thickness of this critical region exposed to corrosion. The embedded remote controls and status LEDs are also perfect for one-person operation.

PEC-TF-400-H05S

Casing	Titanium thin blade
Number of channels	1 channel (Single-element)
Wall thickness	6-25mm (0.25-1.00in)
Footprint zero liftoff	35mm (1.38in)
Liftoff	Up to 13mm (0.5in)
Encoder	Compatible with external encoder
Total blade length	400mm (15.7in)
Hardware compatibility	Compatible with all models
Minimal software requirements	Lyft-Go 1.2+

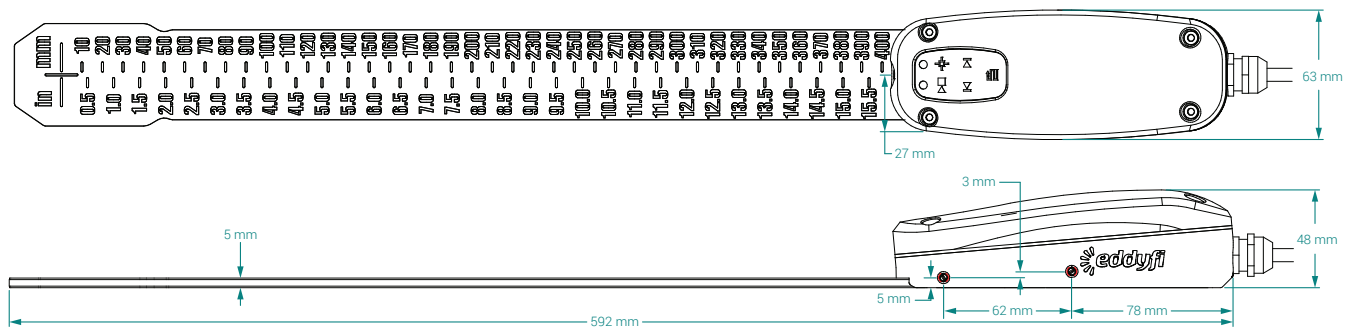
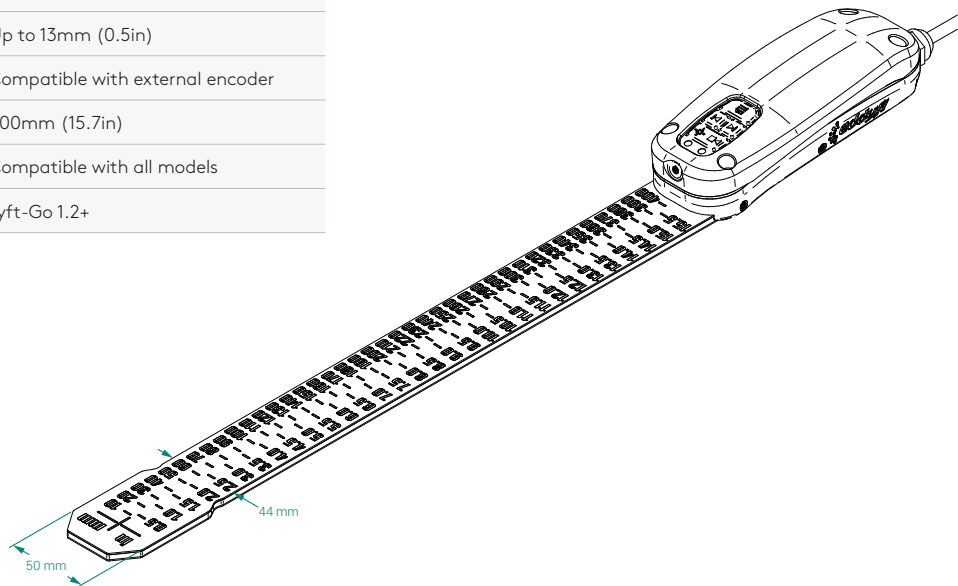
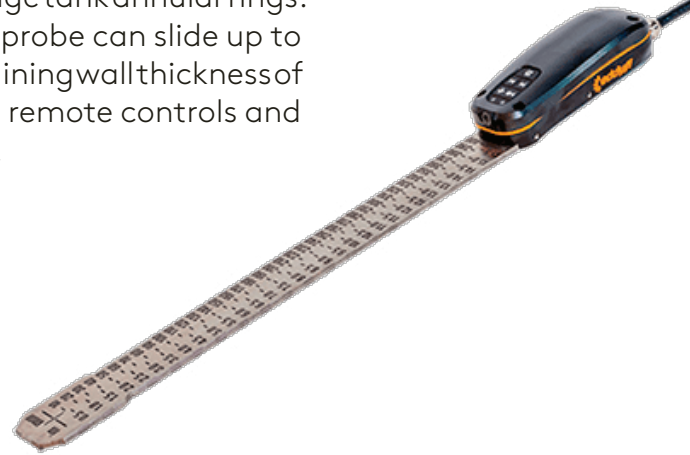

ACCESSORIES

ENCODER

High-precision encoders designed for PECA and PEC probes. They connect directly to probes without the need for an external cable.

PECA-MED-ENC

Resolution	16.04 counts/mm (407.44 counts/in)
Maximum surface temperature	70°C (158°F)
Compatibility	PECA probe

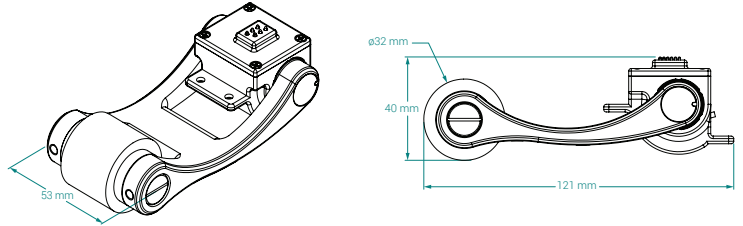

ENC-PEC-STD

Resolution	16.04 counts/mm (407.44 counts/in)
Maximum surface temperature	70°C (158°F)
Compatibility	G2 single-element PEC probes

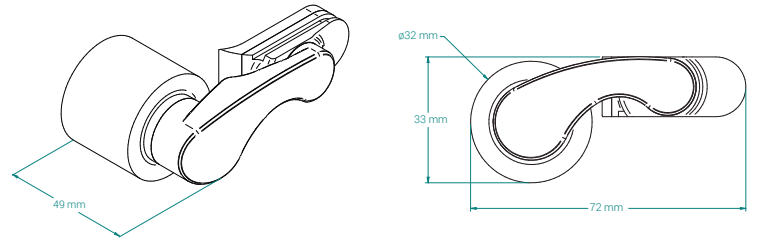

SCAN GRID MAT

The mat features a 25 mm (1 in) resolution grid and enables easier dynamic scans of irregular surfaces and component marking during the inspection setup. The mat is suitable for in-contact operation on surfaces as hot as 70°C (160°F).

PEC-MAT

Dimensions (W x H x D)	813 x 457 x 1.6 mm (32 x 18 x 0.06 in)
Grid resolution	25 mm (1 in)
Maximum surface temperature	70°C (160°F)

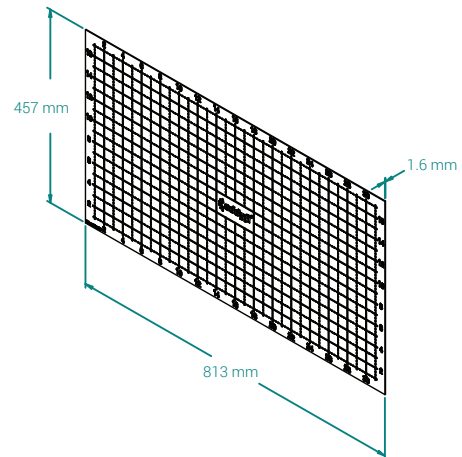

SINGLE-ELEMENT PROBE SHOES

These shoes are designed to enable direct-contact operation on surfaces as hot as 120°C (248°F) and to attenuate the vibration from galvanized steel weather jackets. The shoes are completely compatible with the optional telescopic extension pole.

PEC-025-G2-SHOE-120

Body	Standard probe shoe
Casing	Small
Maximum surface temperature	120°C (248°F)
Compatibility	PEC-025-G2-HT05S

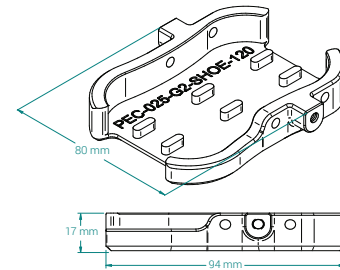

PEC-089-G2-SHOE-120

Body	Standard probe shoe
Casing	Medium
Maximum surface temperature	120°C (248°F)
Compatibility	PEC-089-G2-HT05S

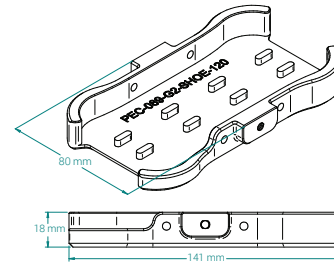

PEC-152-G2-SHOE-120

Body	Standard probe shoe
Casing	Large
Maximum surface temperature	120°C (248°F)
Compatibility	PEC-152-G2-HT05S

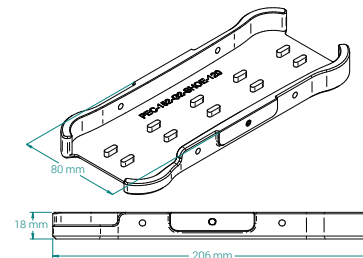

CLIP-ON STABILIZER

This accessory is compatible with second-generation single-element PEC probes. It is used to stabilize grid-mapping scans on very irregular surfaces.

PEC-STAB

Body	Standard stabilizer
Compatibility	G2 single-element PEC probes

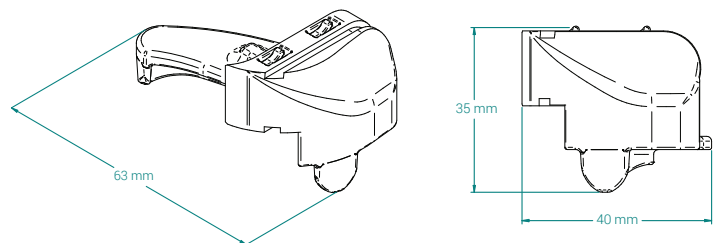

CLIP-ON HANDLES

These ergonomic handles are designed to make manipulating single-element PEC probes easier. The clip-on design makes installing and removing the handles extremely easy.

PEC-089-HANDLE	
Body	Standard probe handle
Casing	Medium
Compatibility	PECA-7CH-SM-H05S, PEC-SF-025-G2-H05B, PEC-089-G2-H05S

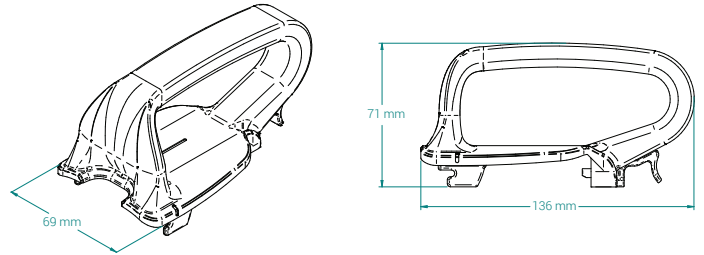

PEC-152-HANDLE	
Body	Standard probe handle
Casing	Large
Compatibility	PEC-152-G2-HT05S

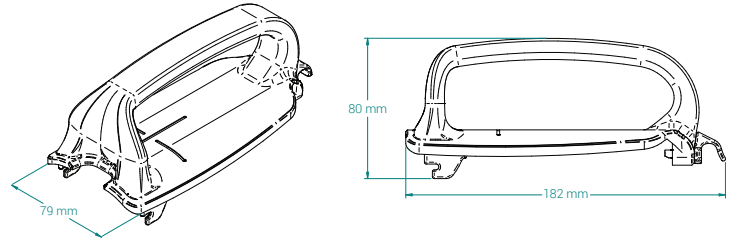

EXTENTION POLE

The pole comes with an adjustable remote control keypad and can extend up to 4.6 m (15 ft). Its adjustable fork enables performing inspections at any angle, on any surface.

PEC-POLE-G2-XH05	
Maximum length	4.6 m (15 ft)
Retracted length	1.8 m (6 ft)
Material (pole)	Fiberglass
Material (fork and remote)	Nylon 11
Compatibility	G2 single-element PEC probes
Total weight (with cable)	3.18 kg (7 lb)

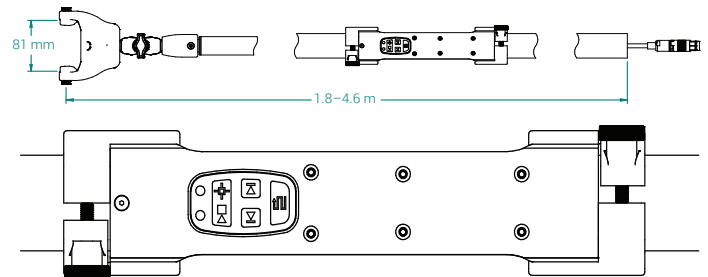

EXTENTION CABLE

Extension cables allow using PECA/single-element PEC probes at a greater distance from the Lyft instrument. Our extension cables are available in lengths of 15 m (50 ft) and 30 m (100 ft). The maximum length of cable between a probe and the Lyft instrument is 35 m (115 ft).

PEC-CBL-XH15 AND PEC-CBL-XH30	
Material	Heavy duty poly
Length	15 m (50 ft) or 30 m (100 ft)
Maximum temperature	H: 80°C (176°F) HT: 120°C (248°F)

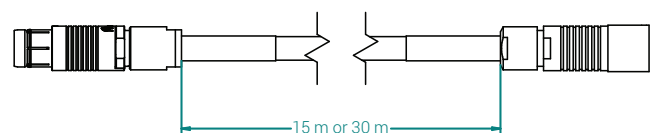

The information in this document is accurate as of its publication. Actual products may differ from those presented herein. © 2023 Eddyfi NDT, Inc. Eddyfi, Grid-As-U-Go, Lyft, and their associated logos are trademarks or registered trademarks of Eddyfi NDT, Inc. in the United States and/or other countries. Eddyfi Technologies reserves the right to change product offerings and specifications without notice.