

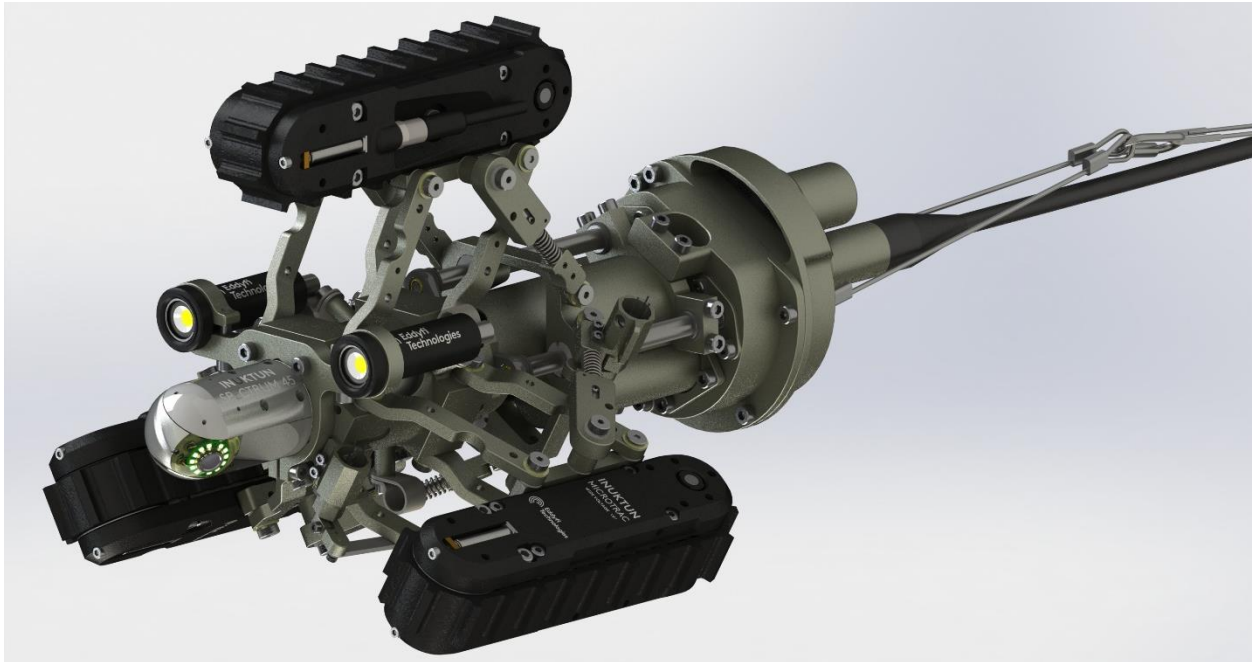

Eddyfi Robotics Inc.  
2569 Kenworth Road, Suite C  
Nanaimo, BC, V9T 3M4  
CANADA

+1.250.729.8080  
info@eddyfitechnologies.com  
www.eddyfitechnologies.com



# TriTrax™ 200

## Vertical Crawler Inspection Vehicle

**Table of Contents**

|   |    |
|---|----|
| About This Manual .....                           | 4  |
| Description .....                                 | 4  |
| Specifications.....                               | 5  |
| Precautions .....                                 | 5  |
| Certification .....                               | 6  |
| Safety .....                                      | 6  |
| Intended Use.....                                 | 7  |
| System Setup .....                                | 8  |
| Personnel Requirements .....                      | 8  |
| Working and Storage Environment.....              | 8  |
| System Power .....                                | 10 |
| Power Requirements .....                          | 10 |
| Generators / Inverters .....                      | 10 |
| ICON™ Portable Controller .....                   | 10 |
| Interface Box Connection .....                    | 10 |
| Vehicle and Tether Connection .....               | 11 |
| Portable Reel Setup.....                          | 13 |
| Mini-Reel Setup .....                             | 14 |
| Tether Handling .....                             | 15 |
| Connector Handling .....                          | 15 |
| SubConn Connector: Lubrication and Cleaning ..... | 16 |
| Impulse Connector: Lubrication and Cleaning.....  | 16 |
| Vehicle Configuration .....                       | 17 |
| Front Camera Removal / Installation .....         | 17 |
| Size Configuration .....                          | 18 |
| Operation.....                                    | 23 |

|   |    |
|---|----|
| Pre-Operations Check .....                        | 23 |
| Post-Operations Check.....                        | 24 |
| ICON™ Software .....                              | 25 |
| ICON™ Control Panel.....                          | 25 |
| Three-Track Operation .....                       | 25 |
| Vertical Crawler Expand & Contact Force .....     | 26 |
| Dealing with Obstacles .....                      | 27 |
| Inspection Guidelines .....                       | 28 |
| Vehicle Recovery.....                             | 28 |
| Troubleshooting .....                             | 29 |
| Camera Control Problems .....                     | 29 |
| Video Problems.....                               | 29 |
| Vehicle Problems .....                            | 30 |
| Reel Problems .....                               | 30 |
| Maintenance.....                                  | 31 |
| Galvanic Corrosion Control.....                   | 31 |
| Rinsing and Cleaning.....                         | 32 |
| Microtrac™ Maintenance.....                       | 32 |
| Camera Maintenance .....                          | 32 |
| Tether Re-termination.....                        | 32 |
| Diameter and Force Feedback Calibration .....     | 33 |
| Diameter Feedback Calibration .....               | 33 |
| Force Feedback Calibration.....                   | 34 |
| Parts and Repairs .....                           | 35 |
| Ordering Parts/Customer Service.....              | 35 |
| Warranty Repairs .....                            | 36 |
| Factory Returns to Canada.....                    | 36 |
| Product/System Drawing Package Availability ..... | 36 |

Limited Warranty Policy ..... 36

## About This Manual

This manual has been prepared to assist you in the operation and maintenance of your Eddyfi Technologies equipment. Correct and prudent operation rests with the operator who must thoroughly understand the operation, maintenance, service and job requirements. The specifications and information in this manual are current at the time of printing.

This product is continually being updated and improved. Therefore, this manual endeavor to explain and define the functionality of the product. Furthermore, schematics or pictorials and detailed functionality may differ slightly from what is described in this manual.

Eddyfi Technologies reserves the right to change and/or amend these specifications at any time without notice. Information in this manual does not necessarily replace specific regulations, codes, standards, or requirements of others such as government or site regulations.

This manual is copyright © 2021 by Eddyfi Robotics Inc. All rights reserved.

## Description

The TriTrax™ 200 Vertical Crawler system is a Microtrac™ 4000 based vehicle used for navigating pipes of 200 – 400 mm (8 – 16 in) internal diameter with the camera centered. The crawler can travel vertically in the pipe up or down.

The inspection system has been manufactured with the hazards and demands of pipe inspection in mind. A minimized vehicle profile provides maximum clearance for passage of service intrusions in the pipe. The vehicle employs marine technology for underwater operation down to a depth of 30 m (100 ft).

The TriTrax™ 200 can also be used in dry environments. The rugged design ensures a long service life and helps protect the vehicle from damage during normal use.

|  |               |                |                   |                  |
|--|---------------|----------------|-------------------|------------------|
| Document: UMDT017749.docm  | Revision: A02 | Created by: JS | Date: 13 Apr 2021 | IPN: 3094329-A02 |
| Source Location: C:\ePDM\ISLEng\Products\DT-VersaTrax100MkII\Manuals\UMDT017749.docm |               |                |                   | Page 4 of 36     |

## Specifications

|                                    |   |   |
|------------------------------------|---|---|
| Minimum Vehicle Dimensions         | Base Configuration: No Spacers                    | Ø200 mm x 425 mm Long (8 x 16.7 in)         |
| Vehicle Weight <sup>1</sup>        | Base Configuration                                | 8.5 kg (19 lb)                              |
| Depth Rating                       |   | 30 m (100 ft)                               |
| Pipe Size Range <sup>2</sup>       | Base Configuration: No Spacers                    | Ø203mm to Ø305mm (8" to 12") pipe           |
|                                    | Extension 50mm (2 inch) spacers                   | Ø305mm to Ø405mm (12" to 16") pipe          |
|                                    | Extension 75mm (3 inch) spacers                   | Ø355mm to Ø455mm (14" to 18") pipe          |
| Min Bend Radius <sup>3</sup>       | 8-Inch Pipe                                       | 610mm (24 in) Radius IN 200 mm (8 in) pipe  |
|                                    | 12-Inch Pipe                                      | 460mm (18 in) Radius IN 305 mm (12 in) pipe |
| Maximum Tether Length <sup>4</sup> |   | 300 m (1,000 ft)                            |
| Tracks                             |   | 3x Microtracs™ 4000                         |
| Camera                             | Front   | Spectrum™ 45 Pan & Tilt                     |
|                                    | Rear  | Onyx™                                       |
| Lights                             |   | 2x 801 Lights                               |
| Reel                               | Optional portable tether reel with payout encoder |   |
| Power Requirements                 |   | 100 – 240 VAC 50/60Hz, 5A                   |
| Operating Temperature              |   | 0 – 40 °C (32 – 122 °F)                     |
| Storage Temperature                |   | -20° – 60 °C (-4 – 140 °F)                  |

<sup>1</sup> Weights may vary depending on optional components

<sup>2</sup> Specified pipe sizes are internal diameters

<sup>3</sup> Using 10-pin Connector. In general, as pipe size increases Min Bend Radius decreases

<sup>4</sup> Actual travel distance may be decreased depending on inspection geometry (traction and number of bends)

## Precautions



**IMPORTANT:** When configuring a 70V system, check to see if the tracks are compatible. Older versions of 4000 series Microtracs™ are not 70V compatible. Look for the Wide Input Voltage symbol  located on the side plate of the track indicating 70V compatibility.

## Certification

The TriTrax™ 200 system is built in accordance with the Low Voltage Directive 2014/35/EU, Machinery Directive 2006/42/EC, and Electromagnetic Compatibility Directive 2014/30/EU.



## Safety

To use this product properly and safely, every user must first read these operating instructions and observe the safety instructions contained therein. Take care of these operating instructions and keep them in a place where they can be accessed by everyone. Untrained personnel should not handle or operate this equipment.



**CAUTION:** Failure to follow these safety instructions may result in injury or equipment damage.



**WARNING: Hazardous Voltage 36-70 VDC.** Do not power the vehicle from any source other than an Eddyfi controller intended for that vehicle.



**WARNING: Intense Optical Radiation** - The Spectrum camera lights, and 801 lights are extremely bright. Never look directly at the lights. Use a welding filter (shade #8 or higher) if inspecting the LEDs.

- When performing maintenance or functional checks of the camera lights, take precautions to protect nearby personnel from unintended exposure which could be temporarily blinding.
- Observe safe lifting practices. For storage and shipping, the TriTrax™ 200 system is packed in three parts: Controller, Vehicle and Tether. Each of the three components is either built or packed into a Pelican case with carrying handle. The heaviest case containing the tether and mini reel is equipped with wheels and extending handle like a suitcase.
- Do not operate the system with damaged wires. A short circuit may damage the power system, telemetry system, cameras, or attached equipment. Exposed wires may also create a shock hazard.
- Disconnect the power source before servicing the product; otherwise, damage may result.
- Although designed for durability, the vehicle and its components or attached devices may suffer structural damage if dropped or impacted. A lifeline or fall arrest system should be used at all time when the vehicle is navigating on a vertical or inverted horizontal position. In addition, stepping on the tether may pull the vehicle off the wall causing it to fall and sustain physical damage.

|  |               |                |                   |                  |
|--|---------------|----------------|-------------------|------------------|
| Document: UMDT017749.docm  | Revision: A02 | Created by: JS | Date: 13 Apr 2021 | IPN: 3094329-A02 |
| Source Location: C:\ePDM\ISLEng\Products\DT-VersaTrax100MkII\Manuals\UMDT017749.docm |               |                |                   | Page 6 of 36     |

- All personnel operating or maintaining this equipment must be trained and competent.
- Eddyfi equipment is used in many varied environments from hot/dry to confined spaces to deep underwater. Such diverse environment risks must be addressed by the operators who are trained to work in such surroundings. As such, the operator is responsible to determine safe site setup, operating procedures and personal protective equipment (PPE) for safe deployment, operation and maintenance of the equipment.



**WARNING: Spark Hazard** - Under no circumstances should this equipment be used in a potentially explosive atmosphere.



**WARNING: Trip Hazard** - Never stand on the tether. A snap load to the tether may pull it out from underneath you and cause you to fall. Standing on the tether may also damage its internal conductors, cause unnecessary wear, and decrease its life.



**WARNING: High Temperature** - The camera head and auxiliary lights may become extremely hot during operation. Allow a cool-down period before handling.



**WARNING: Mechanical Pinch Hazard** – Rotating or moving components can draw fingers into a pinch position. Do not handle the vehicle while mobile parts are running, turn off power or disconnect the tether while reconfiguring or maintaining the vehicle.

## Intended Use

The TriTrax™ 200 is an industrial inspection vehicle intended for crawling vertically or horizontally inside pipes which may be dry or flooded up to 30m (100 ft.)

Typical applications include inspection of:

- Sewer and storm drains
- Hydroelectric pipe and infrastructure
- Steam headers
- Tanks and pressure vessels
- Oil and gas refineries and pipelines
- Pulp and paper mills

|  |               |                |                   |                  |
|--|---------------|----------------|-------------------|------------------|
| Document: UMDT017749.docm  | Revision: A02 | Created by: JS | Date: 13 Apr 2021 | IPN: 3094329-A02 |
| Source Location: C:\ePDM\ISLEng\Products\DT-VersaTrax100MkII\Manuals\UMDT017749.docm |               |                |                   | Page 7 of 36     |

Misuse of the system is deployment in a situation for which it is not rated, or incorrect handling.

Examples of misuse include:

- In a vacuum
- Beyond its depth rating without factory approval
- Above or below its temperature rating
- Use in a potentially explosive atmosphere
- Use in incompatible chemical environments
- Very high radiation environments (Beta / Gamma)
- Prolonged overload (Payload or pulling load)
- Camera pointed at the Sun or at intense lighting

## System Setup

### Personnel Requirements

Basic deployment of the TriTrax™ 200 system may be performed by one person. Operations at more complex worksites may require two people, especially when the console location is removed from the point of deployment.

- **Console Operator:** This person is responsible for driving the vehicle, watching the pipe and making comments about the location and pipe condition. It is also the operator's responsibility to assess whether a pipe is in the appropriate condition for safe passage of the vehicle or if there is a risk of getting stuck. The operator may also assist in general site setup (cones, warning signs, etc.), vehicle maintenance and configuration.
- **Deployment / Tether Handler / Field Maintenance:** This person has several tasks including:
  - Configuring the vehicle for the current pipe
  - Lowering the vehicle in and out of the manhole
  - Watching the tether as the vehicle enters and exits the pipe
  - Operating the reel and winding the tether during recovery

Establish a good channel of communication between the operator and deployment personnel. Good communication can avoid accidents, damage to the equipment, and promotes efficiency and productivity. In particular, the person deploying the vehicle and watching the tether must be able to quickly tell the operator to stop the vehicle if something goes wrong. The operator should never turn on power or initiate movement without first communicating with the vehicle handler.

### Working and Storage Environment

The control system (IC™ 450 Portable Controller or Interface Box and Control computer) is to be used in a **dry, covered** environment only. These components are not waterproof. Keep all cords and cables away from water.

|  |               |                |                   |                  |
|--|---------------|----------------|-------------------|------------------|
| Document: UMDT017749.docm  | Revision: A02 | Created by: JS | Date: 13 Apr 2021 | IPN: 3094329-A02 |
| Source Location: C:\ePDM\ISLEng\Products\DT-VersaTrax100MkII\Manuals\UMDT017749.docm |               |                |                   | Page 8 of 36     |



The **tether and vehicle** are depth rated to 30 m (100 ft) of water. The tether connector is a wet-mate type which may be wet when plugged in but cannot be plugged in underwater. Keep the tether connector capped with a dummy plug when not connected to the vehicle to help keep out dirt. The tracks are tolerant to sandy and muddy conditions, although this decreases seal life. The vehicle may also be operated in dry or dusty environments.

The portable reel is splash resistant only. Refer to the reel manual.

To maximize component life and minimize deployment time it is recommended that the vehicle and tether be cleaned after use and the entire system stored in a dry, dust free, location.

Refer to the Specifications section for operating and storage temperatures.

|  |               |                |                   |                  |
|--|---------------|----------------|-------------------|------------------|
| Document: UMDT017749.docm  | Revision: A02 | Created by: JS | Date: 13 Apr 2021 | IPN: 3094329-A02 |
| Source Location: C:\ePDM\ISLEng\Products\DT-VersaTrax100MkII\Manuals\UMDT017749.docm |               |                |                   | Page 9 of 36     |

## System Power

### Power Requirements

The TriTrax™ 200 is operated through an IC™ 450 Portable Controller or Interface Box. The interface box provides power to the tether and vehicle. Refer to the **ICON™ Portable Controller User Manual** for input power ratings.

### Generators / Inverters

If powering the system from a generator or inverter, refer to that unit's operating manual for recommendations on continuous and peak load ratings. These power sources may apply a reduced output rating based on electrical load and environmental temperature. Remember to include the power needs of any other connected devices (external monitors, recording devices, lighting, etc.) when selecting a generator or inverter.

### ICON™ Portable Controller

The ICON™ portable controller is a combined PC-Based vehicle controller and power supply. No other equipment is required to operate the vehicle. Refer to the Controller Setup section of the **ICON™ Portable Controller User Manual** for instructions on connecting a vehicle to the controller.

### Interface Box Connection

Optionally, the TriTrax™ 200 may be operated through a PC or laptop computer running ICON software. To connect to and power the vehicle, an interface box is required. To set up an PC based control system with an Interface box, do the following;

Set-up:

1. Connect the interface box to AC power using an equipment power cord.
2. Connect the tether (or reel deck cable).
3. Connect the communication port to the control computer using a USB cable.
4. Connect video equipment as needed (monitors, recording devices, etc).
  - a. Front camera: Top row RCA jacks A, B, C.
  - b. Rear camera: Bottom row RCA jacks D, E, F.

The interface box may be ordered with optional features such as video capture to USB or video format conversion. Additional connectors may be present on the rear center panel of the enclosure.

1. Connect SD Video A port to control computer using USB3 cable for front camera video capture.
2. Connect SD Video B port to control computer using USB3 cable for rear camera video capture.



**IMPORTANT:** USB3 cables are required for video capture (SD VIDEO A / B) to maintain video quality.

|  |               |                |                   |                  |
|--|---------------|----------------|-------------------|------------------|
| Document: UMDT017749.docm  | Revision: A02 | Created by: JS | Date: 13 Apr 2021 | IPN: 3094329-A02 |
| Source Location: C:\ePDM\ISLEng\Products\DT-VersaTrax100MkII\Manuals\UMDT017749.docm |               |                |                   | Page 10 of 36    |

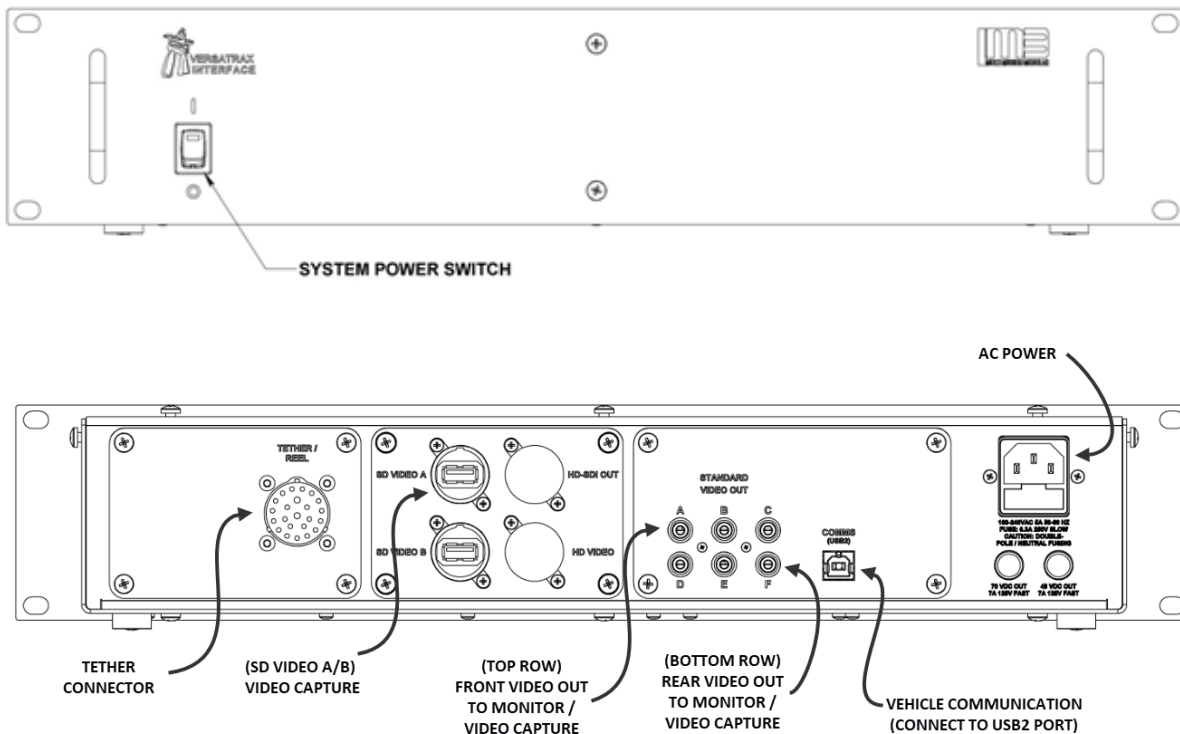

## Vehicle and Tether Connection

It is important that the tether be properly connected to the vehicle – otherwise damage or loss of the system may result.

1. Connect the vehicle end of tether to the back of the vertical crawler. Visually line up the key in the connector before mating. Fully screw down and hand-tighten the locking collar. Do not use tools because the connector can then be easily be overtightened.
2. Secure both lanyards to the Kellems grip using a quick link as illustrated below. Adjust the Kellems grip position to maintain a small amount of slack tether regardless the direction the tether is pulled.
3. Verify all device whips from the harness block to their respective components are securely connected, and the whips are free from damage.
4. Ensure all unused connectors are capped with dummy plugs to insulate and protect their electrical contacts.

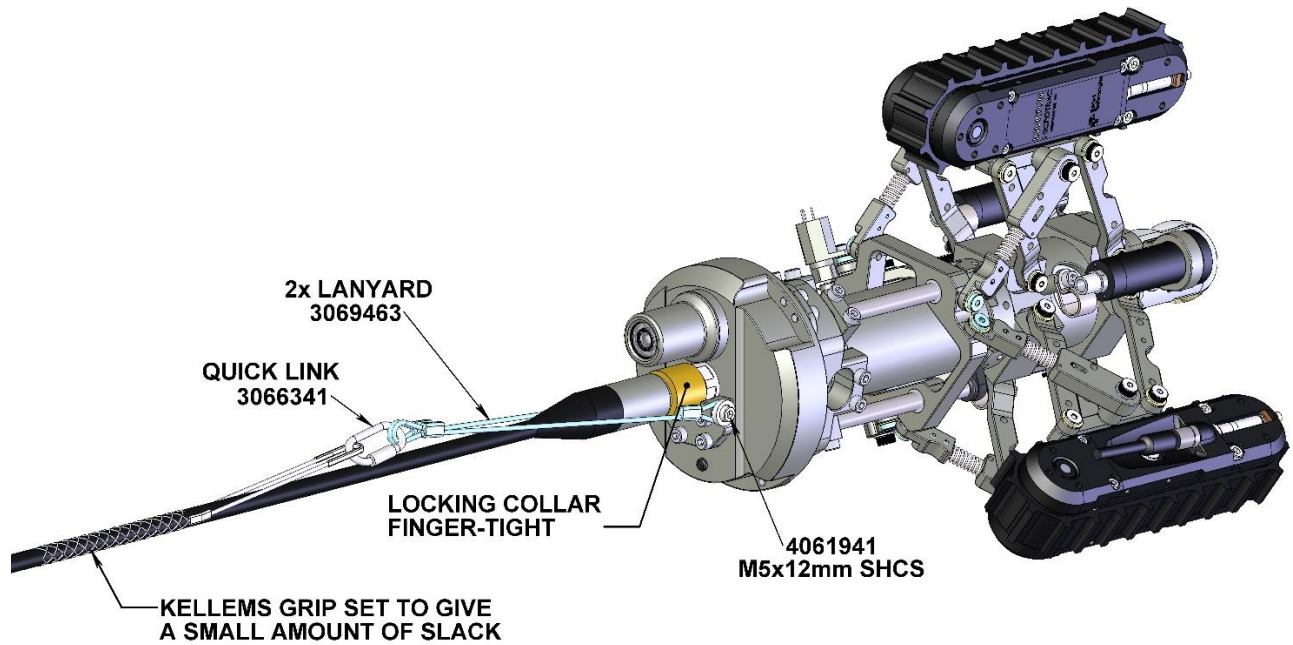

## Portable Reel Setup

If your system includes a portable reel, follow these steps to operate:

1. Remove the shipping cap from the front of the case and insert the crank handle.
2. Connect the deck cable from the reel to the controller.
3. Disengage the packing brake (pull back and turn on the locking pin).
4. Make sure the friction brake is **engaged** - disengaging the friction brake can result in slack tether resulting in potentially jamming the reel.
5. Unwind some tether and connect the tether to the vehicle.
6. Run the tether through the level wind as follows:
  - a. There is an access slot which must be opened by lifting up on the two exposed screw heads to raise the tether support shafts.
  - b. Pull up on both sides of the axle on the top wheel and slide the tether beneath it - failing to lift up on the wheel can scuff and damage the tether.
  - c. Make sure that the two wheels that sandwich the tether top and bottom in the level wind are tracking properly as the tether is paid out - this tells the controller how much tether the reel has unwound and how far your vehicle has travelled.

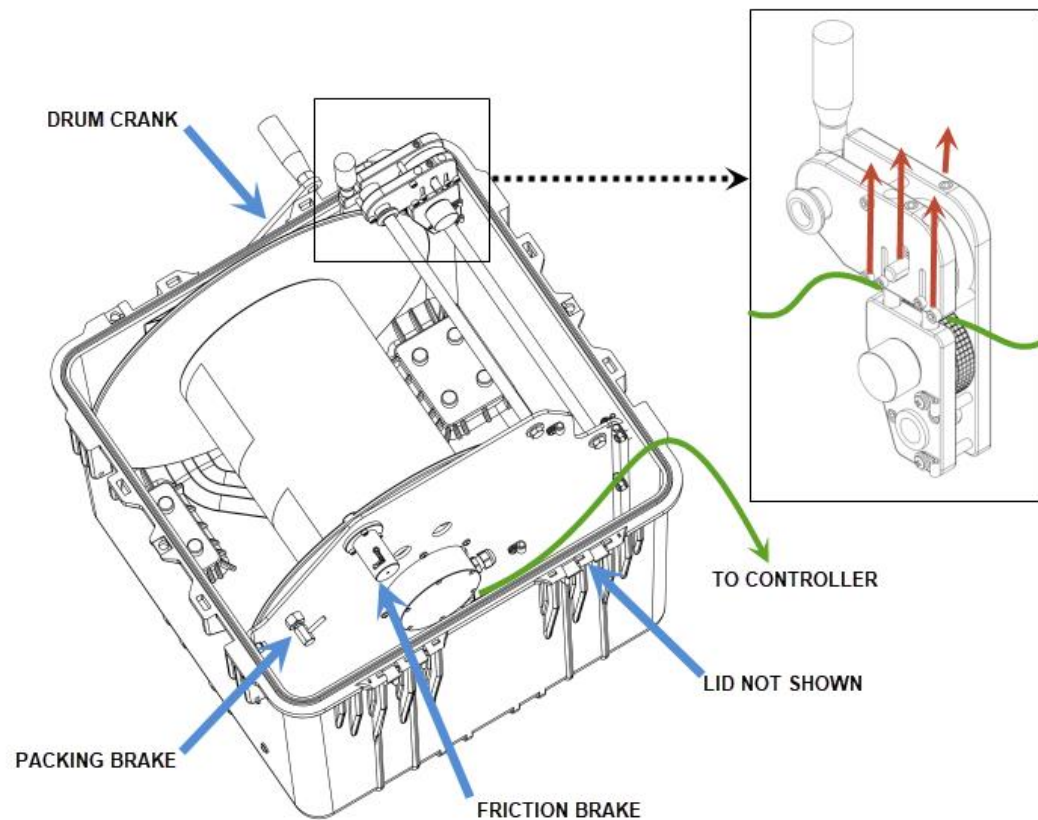

## Mini-Reel Setup

If your system includes a Mini-Reel, follow these steps to operate:

1. Remove the Mini-Reel from the shipping case.
2. Connect the deck cable from the reel to the Video Interface and Power Supply.
3. Connect the encoder deck cable from the reel to the Video Interface and Power Supply (if provided with Mini-Reel).
4. **Disengage** the shipping brake.
5. Make sure the friction brake is **engaged** – disengaging the friction brake can result in slack tether resulting in potentially jamming the reel.
6. Unwind some tether and connect the tether to the vehicle.

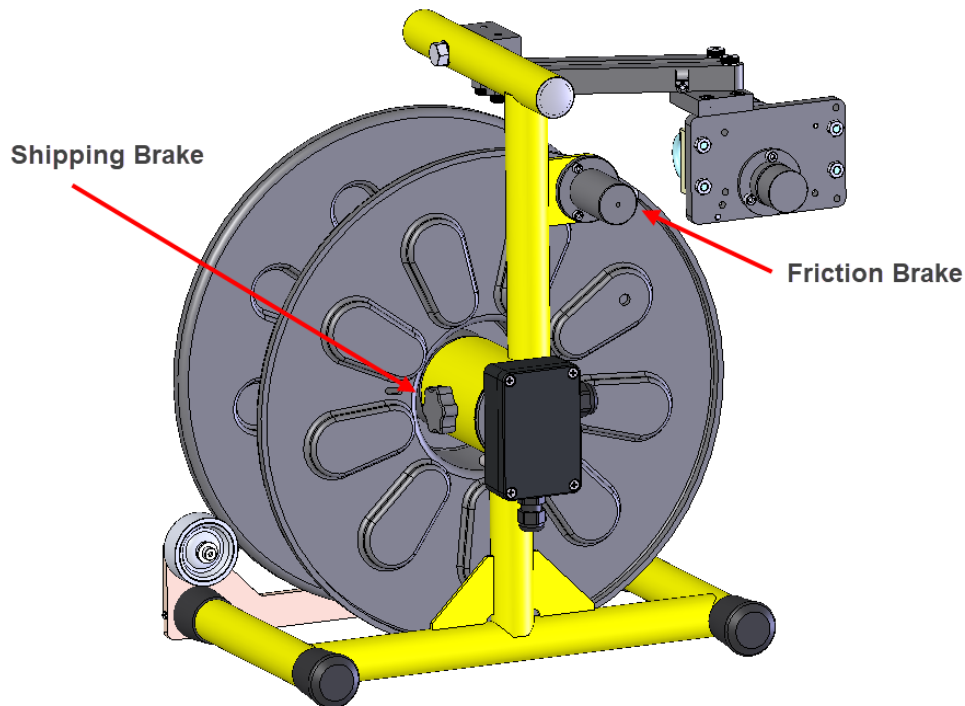

## Tether Handling

**The tether is a very important part of the vehicle system.** It feeds power and control signals to the system and returns data to the controller. If the tether is damaged from improper use, poor handling or an accident, the system may become inoperable. This could lead to significant downtime, loss of production, and avoidable costly repairs. It is encouraged to stress the importance of the tether and its use to anyone operating or maintaining the system. For maximum tether life and reliability, we recommend the following tether handling tips.

- Do not step on the tether
- Do not drive over the tether
- Do not bend the tether beyond its minimum bend radius
- Do not kink the tether
- Do not snap load the tether
- Avoid loading the tether whenever possible
- Always use the cable grip strain relief if applicable to your system
- Regularly inspect the tether for damage
- Regularly clean the tether

**Note:** Protecting the conductors inside the tether is critical to the life and operation of the tether. Proper tether handling and care will result in extended tether life and system reliability.

## Connector Handling

Connectors are an essential part of system reliability. They must be properly maintained and cared for to ensure long life and reliability. It is recommended to follow these steps to help prevent damage and increase the life of connectors.

- Always put the cap back on the tether bulkhead when the tether is disconnected
- Always inspect the end of the connector prior to engaging
- Never plug in a dirty or damaged connector
- Visually align keyways or locating pins prior to engaging the connector
- Always fully engage or tighten the connector
- Secure locking collars finger tight
- Install dummy plugs on unused connectors
- Disconnect by pulling straight, not on an angle
- Do not pull on the cable to disengage the connector



**IMPORTANT:** Never “Hot Plug” any connector, this will result in internal damage to the electronics. Power down the system prior to connecting the tether or any of the modular components.

|  |               |                |                   |                  |
|--|---------------|----------------|-------------------|------------------|
| Document: UMDT017749.docm  | Revision: A02 | Created by: JS | Date: 13 Apr 2021 | IPN: 3094329-A02 |
| Source Location: C:\ePDM\ISLEng\Products\DT-VersaTrax100MkII\Manuals\UMDT017749.docm |               |                |                   | Page 15 of 36    |

**Note:** Never use WD-40 or similar solvent-based fluids on connectors or crawlers. These will cause the rubber parts of the connector or crawler to soften and swell rendering them inoperable.

### SubConn Connector: Lubrication and Cleaning

- Periodically apply Molykote 111 silicone grease or equivalent before mating connectors
- For dry mate connections, a layer of grease corresponding to 1/10 the socket depth should be applied to the female connector
- After greasing, fully mate the male and female connector and remove excess grease from the connector joint
- General cleaning and removal of sand or mud on a connector should be performed using a spray-based contact cleaner like isopropyl alcohol

### Impulse Connector: Lubrication and Cleaning

- Lubricate mating surfaces regularly with 3M Silicone spray or equivalent, DO NOT GREASE
- Lubricate O-rings with Molykote 111 or equivalent
- Use dust caps to protect connectors wherever possible
- Clean connectors with soap and fresh water, rinse out with alcohol and allow connector to air dry before using.



## Vehicle Configuration

### Front Camera Removal / Installation

The Spectrum™ 45 and lights are held onto the vehicle using a simple clamping fixture. To remove the camera or a light, loosen the clamping M5 x 12 mm SHCS and slide the camera or light out of the fixture as shown below. When reinstalling, ensure the connectors and locking collars are fully engaged – *make sure to properly align the pins on the mating connectors.*

THIRD MICROTRAC AND SOME OTHER PARTS  
REMOVED FOR CLARITY

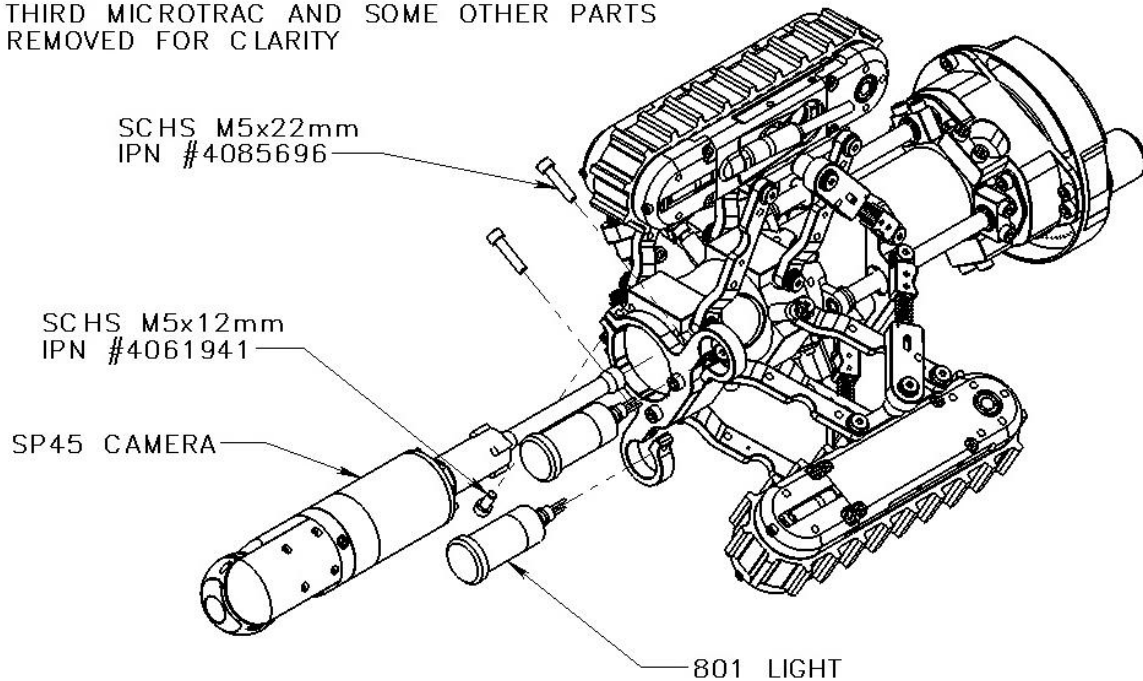

## Size Configuration

**Track Spacers:**

Tracks on TriTrax™ 200 vehicle are remotely adjustable within a 100mm (4-inch) range. To engage the full range of pipe diameters, two sizes of spacers are used as follows:

- a. Base Configuration: No spacers: Ø203mm to Ø305mm (8" to 12") pipe
- b. Extension 50mm (2 inch) spacers: Ø305mm to Ø405mm (12" to 16") pipe
- c. Extension 75mm (3 inch) spacers: Ø355mm to Ø455mm (14" to 18") pipe

Note that a 100mm (4 inch) spacer is optionally available but may compromise vehicle stability.

**Microtrac Belt Extensions:**

- **Standard Length Microtrac** - For the Base 12-inch configuration, the Microtracs are configured with their standard-length belts.
- **Extended Length Microtrac** – Configurations using 2, 3, or 4-inch spacers require the Microtrac belt extensions to ensure vehicle stability.

**Base Configuration Ø203mm to Ø305mm (8" to 12") pipe:** In the base configuration, Microtracs are connected directly to the expansion linkages as illustrated below using the side mounting holes. Note that all tracks are connected to the linkages in the same way, whether configured for left or right-hand operation. Also note that tracks are equipped with the standard length track belt for compact operation.

To assemble the base configuration, do the following as shown below:

1. Connect the front follower linkages using M6x8mm low profile shoulder screws (IPN 3054251) with plastic spring washers beneath the heads.
2. Connect the rear follower linkages using M6x8mm shoulder screws with plastic spring washers (IPN 3054250) beneath the heads.
3. Connect the drive linkages last using M6x20mm (IPN 3054252) shoulder screws.
4. Connect the track connector – *make sure to align the mating pins correctly.*
5. Repeat this procedure for each of the other two tracks.

*Track removal is the opposite of installation*

|  |               |                |                   |                  |
|--|---------------|----------------|-------------------|------------------|
| Document: UMDT017749.docm  | Revision: A02 | Created by: JS | Date: 13 Apr 2021 | IPN: 3094329-A02 |
| Source Location: C:\ePDM\ISLEng\Products\DT-VersaTrax100MkII\Manuals\UMDT017749.docm |               |                |                   | Page 18 of 36    |

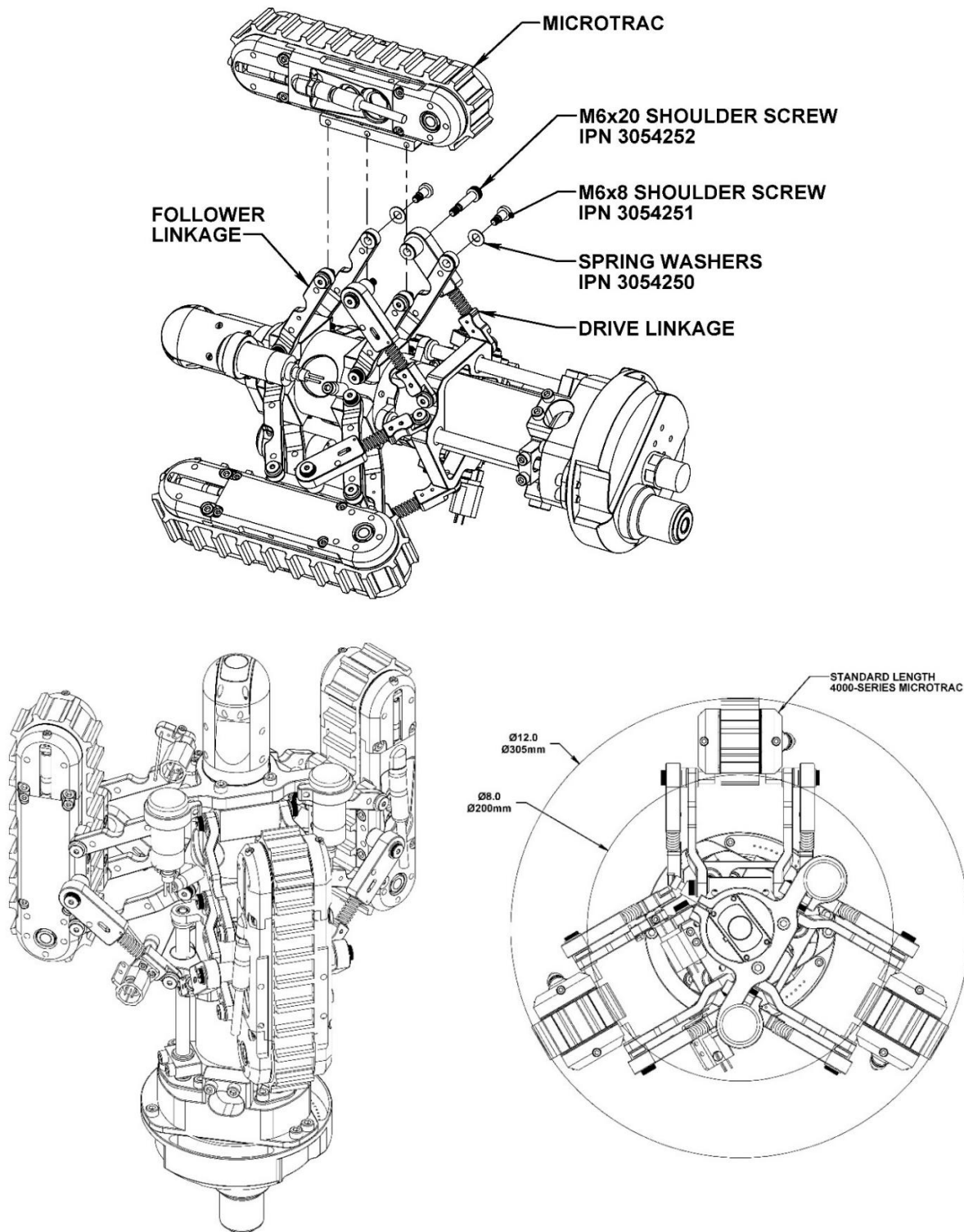

Figure 1: 203mm-305mm (8 to 12 Inch) Configuration.

|  |               |                |                   |                  |
|--|---------------|----------------|-------------------|------------------|
| Document: UMDT017749.docm  | Revision: A02 | Created by: JS | Date: 13 Apr 2021 | IPN: 3094329-A02 |
| Source Location: C:\ePDM\ISLEng\Products\DT-VersaTrax100MkII\Manuals\UMDT017749.docm |               |                |                   | Page 19 of 36    |

**Extended Configurations:** To increase the operating size range, install the 50mm (2 inch) or 75mm (3 inch) extension brackets onto the linkages. Note that the extended length track belt is installed for increased vehicle stability in large diameter pipes.

To install either size of extension brackets, do the following as shown below:

1. Fasten either the 50 (2 inch) or 75mm (3 inch) track spacer to the spacer base using 4x M5x16mm Flat Head Machine Screws.
2. Attach the Microtrac to the extension bracket using 4x M5x10mm Socket Head Cap Screws.
3. Attach the spacer base to the expansion linkages as detailed in the previous section.
4. Ensure there is enough cable fed through the chassis to plug in the track. Wires can generally be secured to the long bushing on the driver linkage using a zip-tie.
5. Connect the track connector – make sure to align the mating pins correctly, and fully engage the locking collar.
6. Repeat this procedure for each of the other two tracks.

*Bracket removal is the opposite of installation*

|  |               |                |                   |                  |
|--|---------------|----------------|-------------------|------------------|
| Document: UMDT017749.docm  | Revision: A02 | Created by: JS | Date: 13 Apr 2021 | IPN: 3094329-A02 |
| Source Location: C:\ePDM\ISLEng\Products\DT-VersaTrax100MkII\Manuals\UMDT017749.docm |               |                |                   | Page 20 of 36    |

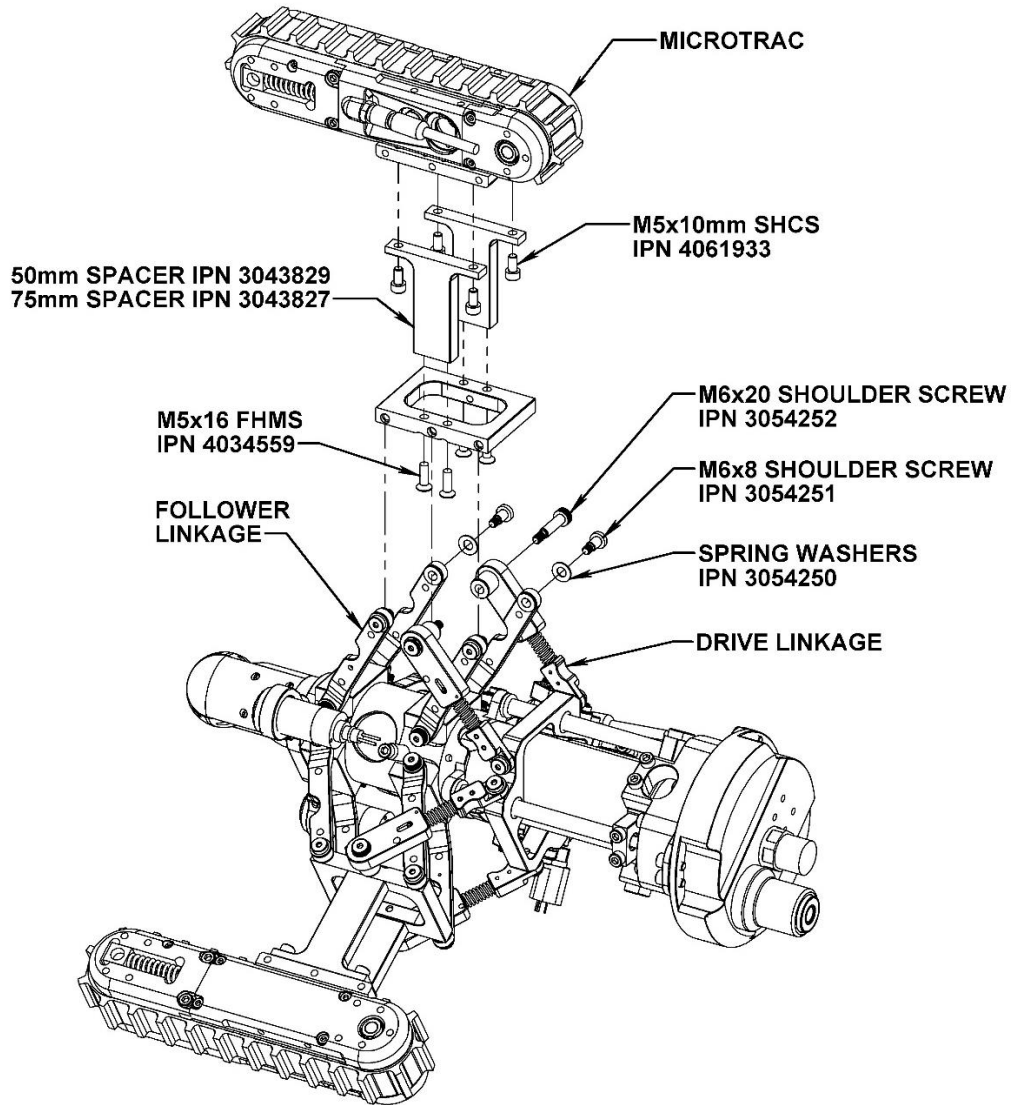

FIGURE 2: 50MM AND 75MM TRACK SPACERS.

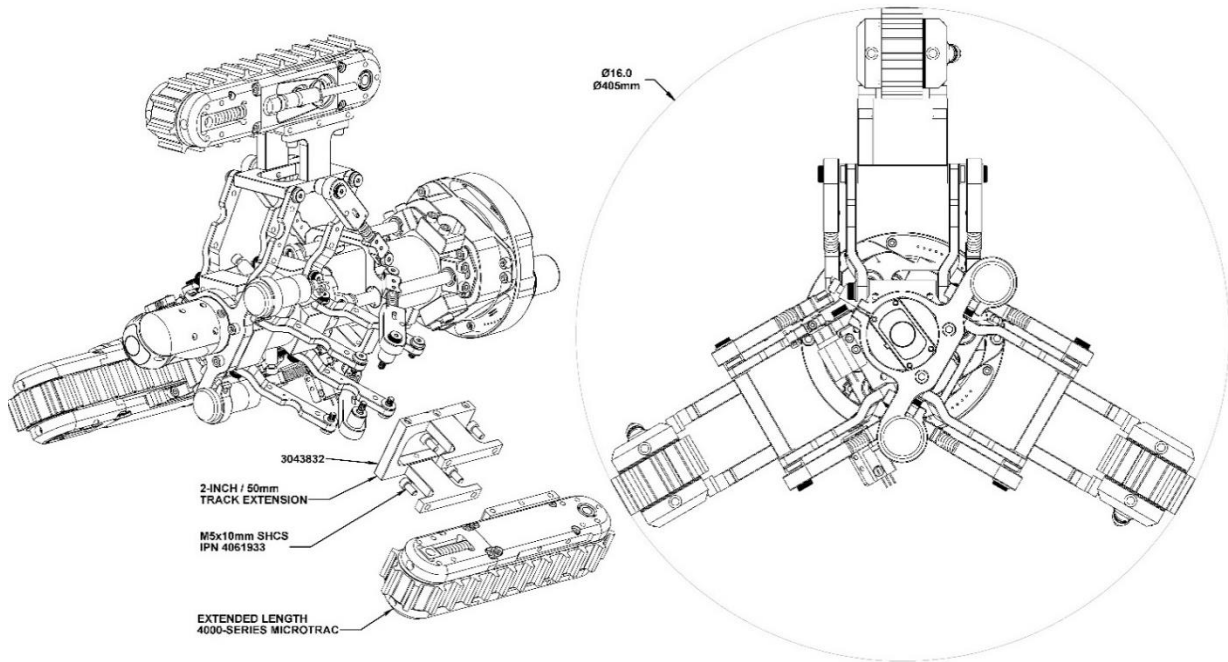

Figure 3: 305mm-406mm (12 to 16 Inch) Configuration.

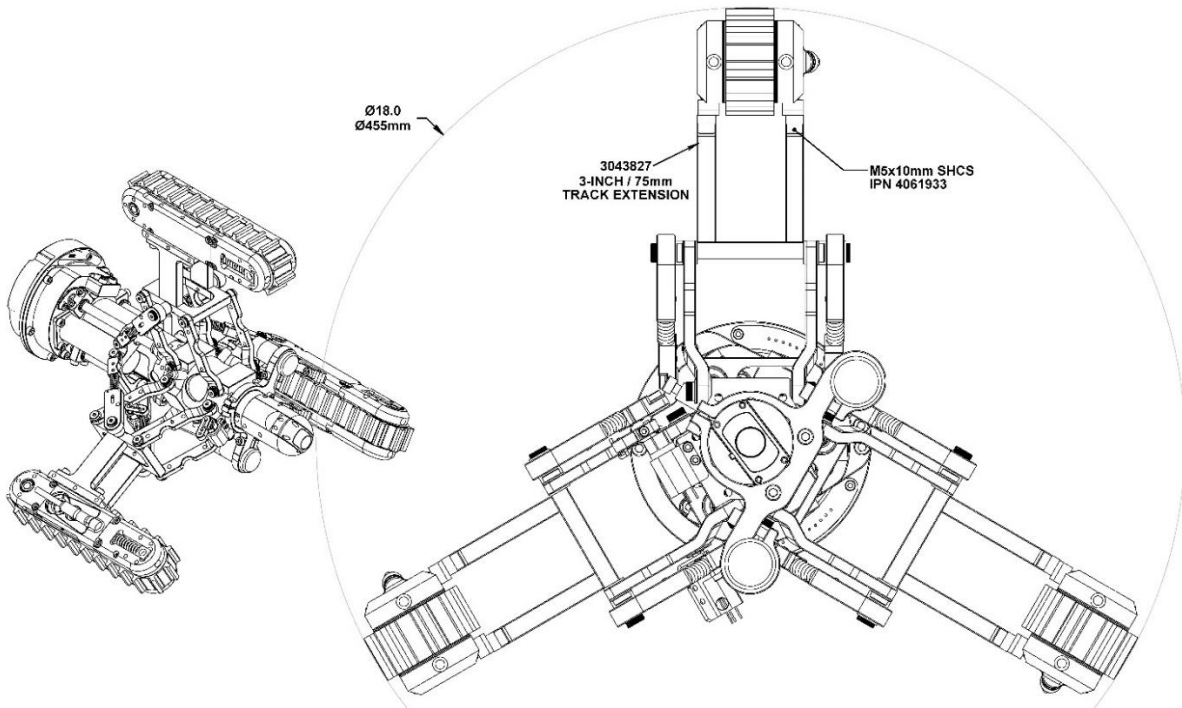

Figure 4: 355mm-455mm (14 to 18 Inch) Configuration.

## Operation

### Pre-Operations Check

Before each deployment of the TriTrax™ 200, ensure everything is completed on the following checklist.

- Check that the work area has been safely set up.
- Check that the line voltage available at the worksite matches the equipment setup.
- Check that power and deck cable connections are correct.
- Check the vehicle for the following:
  - Check that the vehicle is in the correct configuration for the deployment.
  - Check the vehicle for mechanical damage to the chassis or cable harnesses which could affect its operation.
  - Ensure that all fasteners are in place and secure. In particular, check the fasteners holding on cameras, lights, tracks, and the harness block.
  - Visually inspect the vehicle and Microtracs™ to ensure that the moving parts are free of debris and functional. Make sure the track belt is free of debris and turns freely.
  - Check the tether and vehicle whips for damage.
  - Ensure camera, light, and laser ports are clean.
- Check the reel for the following:
  - Check that nothing will block movement of the level wind shuttle.
  - Check that the tether has no loose, dangling coils. Dangling coils can propagate as the drum rotates and have the potential to jump the drum. Take care of these before deploying the tether.
- Power up the system and check the following:
  - Check for sufficient SSD drive space for recording.
  - Check record directories are set.
  - Test video recording.
  - Test auxiliary lights.
  - Test track control.
  - Test camera control.

**Post-Operations Check**

A Post-Ops inspection should be carried out after every deployment using the following checklist:

1. Inspect the tether for damage as it is reeled in.
2. Visually inspect vehicle for entrained debris or mechanical damage.
3. Test each function to ensure proper operation.
4. Clean the system by hosing it down with water at regular line pressure. Do not pressure wash. The tracks may be cleaned off by hosing them down while running. If the system has been used in saltwater, thoroughly rinse the vehicle with fresh water right away.



**CAUTION:** Do not use a pressure washer to clean the camera. Very high-pressure water can push past seals and flood the camera resulting in electrical damage or personal injuries.

5. Take time to pack the system properly for transport away from the worksite.
6. Store the system in a dry environment.

**Note:** Ensuring the TriTrax™ 200 system is always stored in good working condition will minimize deployment time for future inspections.

|  |               |                |                   |                  |
|--|---------------|----------------|-------------------|------------------|
| Document: UMDT017749.docm  | Revision: A02 | Created by: JS | Date: 13 Apr 2021 | IPN: 3094329-A02 |
| Source Location: C:\ePDM\ISLEng\Products\DT-VersaTrax100MkII\Manuals\UMDT017749.docm |               |                |                   | Page 24 of 36    |



## ICON™ Software

Vehicle control, video recording and export are accomplished using ICON graphical interface controller software. The manual for ICON is integrated into the software or available in PDF format on the control computer's desktop.

- ICON Manual – Accessed through ICON or Desktop Shortcut.

## ICON™ Control Panel

The TriTrax™ 380 Vertical Crawler is operated using the ICON™ Software vehicle control panel.

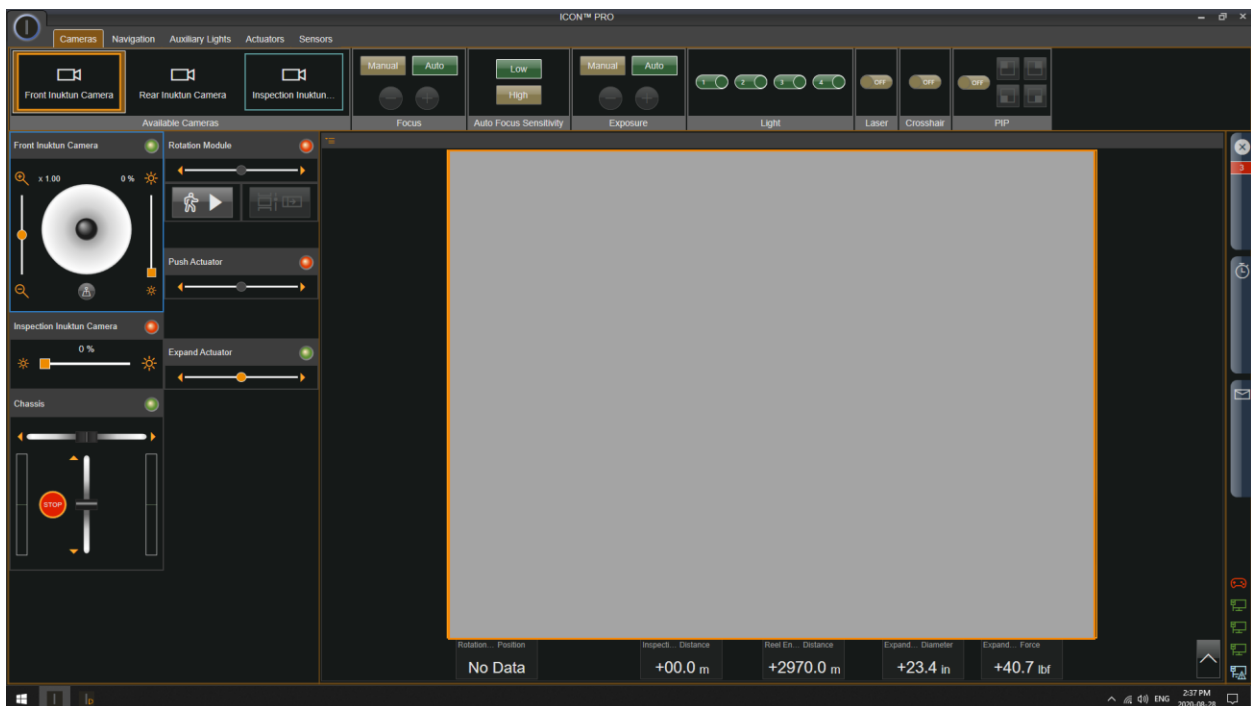

## Three-Track Operation

The three-track tripod arrangement of the TriTrax™ 200 presents a unique control task to the operator. The bottom two tracks work as an ordinary tractor pair controlled by the ICON track joystick control. The joystick is used as with any tractor pair to guide the vehicle forward, backwards and around corners. ICON automatically runs the third track at the average speed of the lower pair. For example, when driving straight forward or straight back, the top track runs forward or backwards at the same speed as the two lower racks. However, when turning, the top track slows to a speed in between the lower two tracks. When executing a spot-turn, the top track does not move at all. With this control arrangement, the vertical crawler operates evenly down straightaways and around corners.

|  |               |                |                   |                  |
|--|---------------|----------------|-------------------|------------------|
| Document: UMDT017749.docm  | Revision: A02 | Created by: JS | Date: 13 Apr 2021 | IPN: 3094329-A02 |
| Source Location: C:\ePDM\ISLEng\Products\DT-VersaTrax100MkII\Manuals\UMDT017749.docm |               |                |                   | Page 25 of 36    |

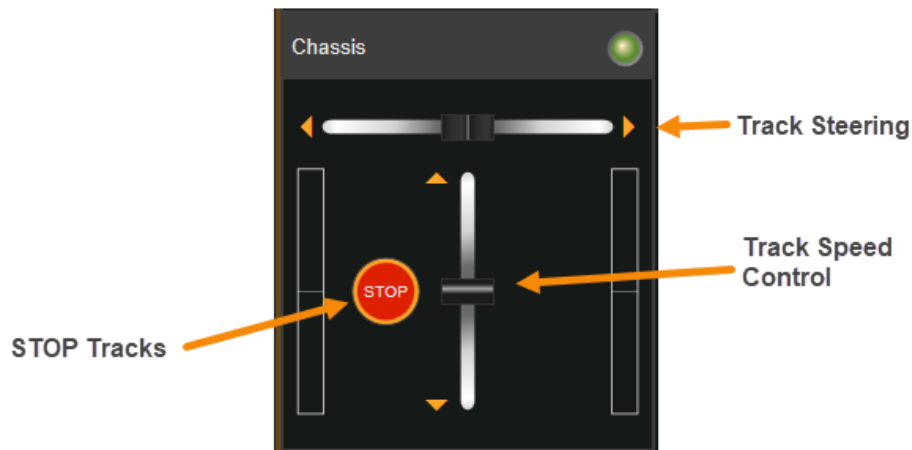

### Vertical Crawler Expand & Contact Force

The TriTrax™ 200 expand mechanism is controlled by the Expand Actuator control window.

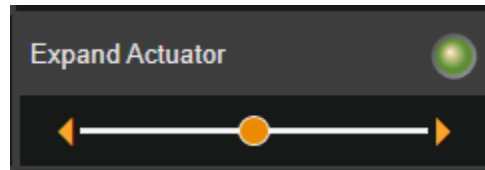

The expansion mechanism is operated using the actuator slider in the ICON interface between 8 and 12" pipe sizes and can go slightly smaller or larger to accommodate insertion and maintain full contact in 12" pipe. Contact force is controlled by expanding the mechanism an additional amount after full contact with the pipe. Springs in the linkage will increase the track pressure as the mechanism expands. The expanded size and contact force are measured at the vehicle and the Instrument panel can be configured to display the measurements for the operator in pounds, newtons or kilograms.

Feedback is internally calibrated for the 8 to 12-inch configuration. When using track height extensions, double the single extension height and add it to the reading. For instance, when using the 2-inch extension bracket, add 4 inches [100 mm] to the diameter.

Because the springs are pre-compressed, there is a minimum contact force that can be registered by the sensor and displayed, regardless of whether contact is made. Beyond the minimum force, the springs will compress allowing true measurement until they bottom out.

|  |               |                |                   |                  |
|--|---------------|----------------|-------------------|------------------|
| Document: UMDT017749.docm  | Revision: A02 | Created by: JS | Date: 13 Apr 2021 | IPN: 3094329-A02 |
| Source Location: C:\ePDM\ISLEng\Products\DT-VersaTrax100MkII\Manuals\UMDT017749.docm |               |                |                   | Page 26 of 36    |

To ensure the vehicle is gripping the pipe, the operator must adjust the force beyond the minimum according to the table below. As seen in the table, the maximum contact force decreases with the pipe size.

| Pipe Diameter |      | Minimum Force |     |      | Maximum Force |     |      |
|---------------|------|---------------|-----|------|---------------|-----|------|
| mm            | Inch | lbf           | N   | kg   | lbf           | N   | kg   |
| 312           | 12.3 | 28            | 125 | 12.7 | 43            | 191 | 19.5 |
| 305           | 12.0 | 27            | 120 | 12.2 | 41            | 182 | 18.6 |
| 279           | 11.0 | 23            | 102 | 10.4 | 34            | 151 | 15.4 |
| 254           | 10.0 | 18            | 80  | 8.2  | 25            | 111 | 11.3 |
| 229           | 9.0  | 14            | 62  | 6.3  | 18            | 80  | 8.2  |
| 203           | 8.0  | 9             | 40  | 4.1  | 10            | 44  | 4.5  |

Do not to allow the contact force to decrease below the minimum or increase beyond the maximum. In these conditions, the TriTrax™ 200 may lose traction and fall, or may become jammed or damaged from excessive force, respectively. In the smaller pipe sizes, it is permissible to go beyond the maximum readable force in order to achieve adequate traction.

Some care must be taken during certain transition maneuvers between pipe sizes, for example:

1. **Crawling upwards, transition from small to large pipe:** This is the safest transition with no danger of falling or mechanism overload.
2. **Crawling upwards, transition from large to small pipe:** This is the most dangerous transition, with danger of falling and mechanism overload. We suggest this maneuver be attempted only in smooth pipe transitions and never in offset transitions.
3. **Crawling downwards, transition from large to small pipe:** This is a relatively safe transition but be sure to reduce the size of the mechanism to prevent overload.
4. **Crawling downwards, transition from small to large pipe:** The crawler will fall until it expands to the next pipe size. This maneuver can be dangerous if the next pipe size is too large for the mechanism. If possible, hold the vehicle back by the tether until the mechanism contacts the pipe again.

## Dealing with Obstacles

The operator will invariably encounter a range of obstacles in a pipe. Each time the operator must decide if the vehicle can safely pass or if there is risk of getting stuck. Common obstacles include but are not limited to:

- Crushed pipe
- Sand
- Rocks, construction debris, random rubbish
- Roots
- Intersecting service pipes

- Animals and their nests

If the operator is unsure about pipe navigability, he or she should consult with the site supervisor before moving forward.

### Inspection Guidelines

The objective of an inspection is to obtain a recording of video and other data for review by the customer or pipe owner. If a recording is lost, fails to record, or is of poor quality the inspection will likely have to be re-done at the operator's expense. Therefore, it is in the operator's best interest to verify vehicle operation, video quality and recorder function before beginning each inspection.

A set of video overlay comments and data are usually required depending on the contract or client. Initial comments will usually include the location, pipe number and date. During the inspection the contractor may require certain pipe features or faults to be pointed out along with the distance from the pipe entry.

Conduct a complete inspection of pipe features and faults. For any feature or situation of interest, stop the vehicle and make a complete video survey using the continuous pan feature of the camera. Ultimately, the inspection is conducted for the benefit of the client who is reviewing the footage later on.

### Vehicle Recovery

In the event the vehicle becomes disabled while on a mission in a pipe, provision has been made for recovery of the vehicle by pulling it out with the tether. Recovering the vehicle by pulling is a serious operation and can put great demand on the tether system. Listed below are three scenarios where the vehicle may need to be recovered. Loading the tether beyond its maximum safe capacity should be considered only as a last resort.

**Note:** Prevention is always the best policy. When traveling through a pipe or in any unknown area, carefully watch your monitor.

The vehicle may become stuck if it is traveling through a damaged pipe section or improperly steered around a corner. If the vehicle does become stuck:

1. Determine if it is the vehicle or the tether that is stuck. Look back at the tether with the camera if possible. If the vehicle can back up but the tether will not reel in, the tether is caught on something. Try to look for and fix the cause of the catch *before* putting any more strain on the tether. The operator should use any dexterity available first to free the vehicle without resorting to force.
2. If the vehicle cannot work itself free from a snag, try using *light* tether tension and tractor power simultaneously.
3. If still stuck, try a stronger tether tension.
4. If the vehicle seems to be permanently stuck in the pipe, the supervisor must decide whether to sacrifice the tether in order to pull harder, or to dig the vehicle out.

|  |               |                |                   |                  |
|--|---------------|----------------|-------------------|------------------|
| Document: UMDT017749.docm  | Revision: A02 | Created by: JS | Date: 13 Apr 2021 | IPN: 3094329-A02 |
| Source Location: C:\ePDM\ISLEng\Products\DT-VersaTrax100MkII\Manuals\UMDT017749.docm |               |                |                   | Page 28 of 36    |

## Troubleshooting

### Camera Control Problems

- Not all the auxiliary lights are on.
  - The ICON software allows the lights to be controlled independently. Ensure all lights are enabled. Refer to the ICON manual.
  - Inspect for blown LEDs.
- Warning: High Intensity. Do not look directly into the lights. Use a welding filter (shade #8) to observe the light elements.
- Camera pan or tilt does not function in one or both directions.
  - Check that the camera is not jammed.
  - If you can hear a motor running but see no movement, there is a mechanical or clutch problem inside the camera. Contact us.
- Camera is moving very slowly.
  - Check the pan & tilt speed in the camera control window. Refer to the ICON user interface manual.

### Video Problems

- No video (black or blue background)
  - Interface box is not turned on.
  - Video cables are not hooked up between interface box and computer.
  - Camera connector on vehicle is loose (turn power off first before plugging in camera).
  - Check that the camera harness whip is plugged into the correct socket on the telemetry can.
  - Check monitor input settings.
- Vehicle power is not on.
  - Check for problems with other video components between the computer and monitor.
  - Try a different monitor. Whole days have been spent on field maintenance trips only to discover a faulty monitor.
- Picture is very dark or very bright.
  - Check the light levels of both the camera and main lights.
- Intermittent picture.
  - Check and replace the video cables.
  - Check the monitor is working properly.
  - Check that the camera harness whip is fully plugged in.
  - Check for intermittent breaks in the camera harness cable.
  - Check the tether connectors at both controller and vehicle.
  - Check for tether or slip ring damage by testing tether continuity.
- Picture is blurry, will not focus, or has poor color.
  - This may be a dirty camera view port, or a narrow object lying in front of the view port.
  - Object may be too close to the camera.
- No Rear Video
  - Verify the video connection from the interface box to the computer.

|  |               |                |                   |                  |
|--|---------------|----------------|-------------------|------------------|
| Document: UMDT017749.docm  | Revision: A02 | Created by: JS | Date: 13 Apr 2021 | IPN: 3094329-A02 |
| Source Location: C:\ePDM\ISLEng\Products\DT-VersaTrax100MkII\Manuals\UMDT017749.docm |               |                |                   | Page 29 of 36    |

- This may be a dirty camera view port, or a narrow object lying in front of the view port.

## Vehicle Problems

- Vehicle won't steer or vehicle runs backward.
  - Tracks set to the wrong positions.
  - Track reverse setting incorrect in control software.
  - Node ID conflict between one or more devices on the vehicle.
- Tracks will not run.
  - Check the track current feedback (See ICON manual).
    - If current is at 100% and the vehicle doesn't move, then the tracks may be jammed. They could be wedged on an object or jammed with sand. Try reversing the tracks to clear debris. If a jam will not clear you will have to recover the vehicle by pulling it out with the tether.
    - If no current registers, then power or communication is not getting to the tracks. Check all the cable connections.
  - Try power cycling the system.
  - Inspect the vehicle wiring for damage.
  - Check all the system connectors.
  - Try restarting ICON.
  - Listen for the track motors. If the motors run but the track doesn't turn, there is a problem with the gearing or shaft pins.
  - Try changing tracks. (ICON will require a restart.)
- Track Raise will not move.
  - Check the linkage between the top linkage and the encoder feedback.
  - Check the connector to the camera raise motor.
  - Try restarting ICON.

## Reel Problems

- Tether distance does not read correctly.
  - Check that the pressure wheel is pressing the tether against the payout sheave. If the tether is being pulled up from the sheave instead of down, it may be disengaged from the sheave.
  - Check that the units are set properly in the graphical overlay.
  - Recalibrate distance encoder.
  - Ensure that the correct COM port is selected in the control software.

## Maintenance

### Galvanic Corrosion Control

Eddyfi Technologies strongly recommends cathodic protection whenever the TriTrax™ 200 is being deployed in a saltwater environment – either submerged or in salt spray, regardless of camera or track material.

Eddyfi Technologies' vehicles are designed to use **aluminum** marine anodes. Aluminum anodes are common in the marine industry and are replacing zinc anodes in many areas. For vehicle systems that are often pulled in and out of the water, aluminum anodes are especially important, as zinc anodes tend to scale over when exposed to air and may not reactivate when submerged again. An aluminum anode will always reactivate.

If the vehicle is being carried by a transport device, for example, a larger ROV, we recommend it also be protected by **aluminum** anodes or the two vehicles be electrically isolated from one another. Do not mix anode types (zinc and aluminum) on the assembly, between vehicles or between structures. There must be only one anode type throughout. Magnesium anodes must never be used with Eddyfi Technologies equipment.

Anodes are installed onto the TriTrax™ 200 as illustrated below and secured with Loctite 243. Contact your sales representative for anode replacements.

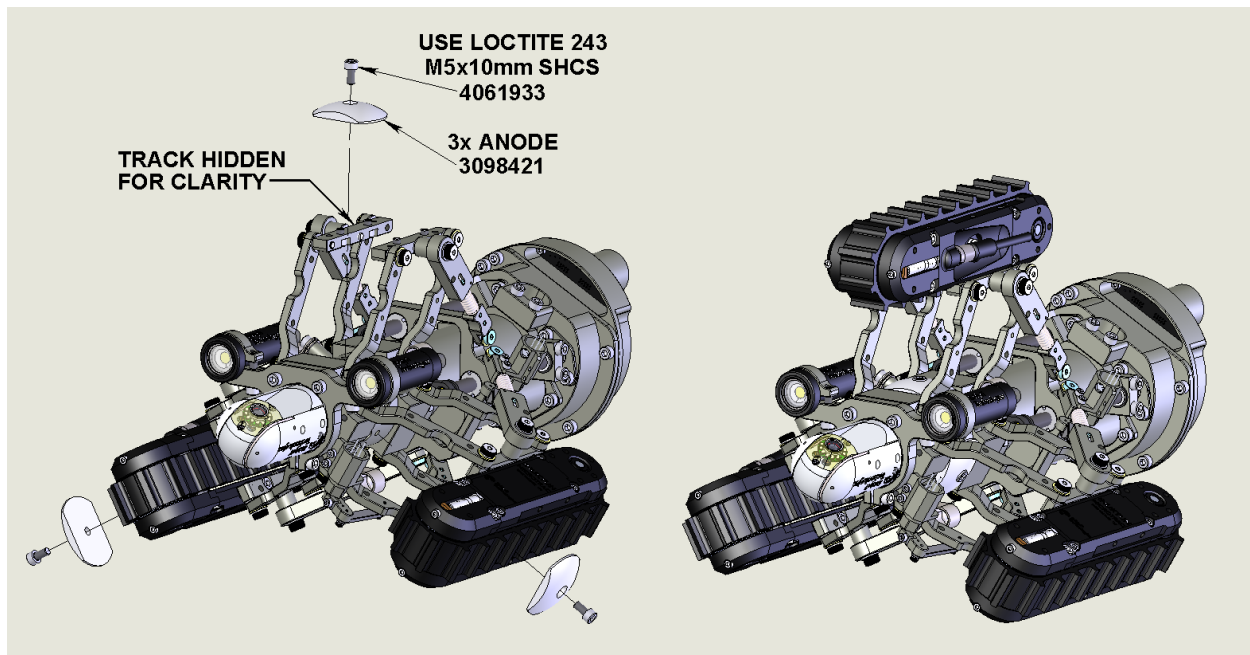

## Rinsing and Cleaning

After every mission check to see if the vehicle needs cleaning.

1. If the system has been used in saltwater, thoroughly rinse the vehicle with fresh water prior to being stored away. Accelerated corrosion will result if the inspection system is not rinsed properly. Pay close attention to rinsing and cleaning the camera window, LED light dome and the spaces between moving parts and track belts.
2. Use an open hose or tap at regular water line pressure for rinsing. Do not pressure wash the equipment – water will be forced into the camera at these high pressures.
3. Avoid scratching the camera port. Use glass cleaner and a soft cloth to clean the port.



**CAUTION:** Do not use a pressure washer to clean the camera. Very high-pressure water can push past seals and flood the components resulting in electrical damage or personal injuries.

Periodically:

1. Use a damp cloth or spray cleaner for the power supply / controller box. The box must never be sprayed down or immersed in water. Unplug the controller before cleaning.
2. For general cleaning of the cameras and tracks, use a mild detergent.

Note that the expansion screws employ plastic ACME nuts for lubricant-free operation and do not require greasing.

## Microtrac™ Maintenance

Refer to the Microtrac manual for maintenance and servicing instructions.

## Camera Maintenance

Refer to the Spectrum™ 45 manual for camera maintenance and servicing instructions.

## Tether Re-termination

Contact us if tether re-termination is required. Tether re-termination kits are also available. Detailed instructions and wiring diagrams will be included with the kit.

|  |               |                |                   |                  |
|--|---------------|----------------|-------------------|------------------|
| Document: UMDT017749.docm  | Revision: A02 | Created by: JS | Date: 13 Apr 2021 | IPN: 3094329-A02 |
| Source Location: C:\ePDM\ISLEng\Products\DT-VersaTrax100MkII\Manuals\UMDT017749.docm |               |                |                   | Page 32 of 36    |



## Diameter and Force Feedback Calibration

Calibration of the diameter and force feedback are performed at the factory. Generally, recalibration of these feedbacks should only be done if a linkage, potentiometer, or other associated parts are being replaced or repaired. Important calibration information:

1. Always use TWO people when calibrating a device. One person to observe the device and the second person to operate the software.
2. Always calibrate at positions close to hard mechanical stops, never at the mechanical stops
3. After a device is calibrated double check that the calibration points are correct and not hitting mechanical stops.

Calibration of the position and force potentiometers is accomplished in ICON backstage.

## Diameter Feedback Calibration

1. Drive the expansion down until the drive screws stops about 13mm from the hard limit. THEN, push down on the linkage by hand to **compress the spring**. This is the linkage minimum diameter. Set **MIN** in ICON.
2. Drive the expansion mechanism up until the ACME drive screws stops about 6mm from the hard limit. (This time, do not compress the springs.) Set **MAX** in ICON.

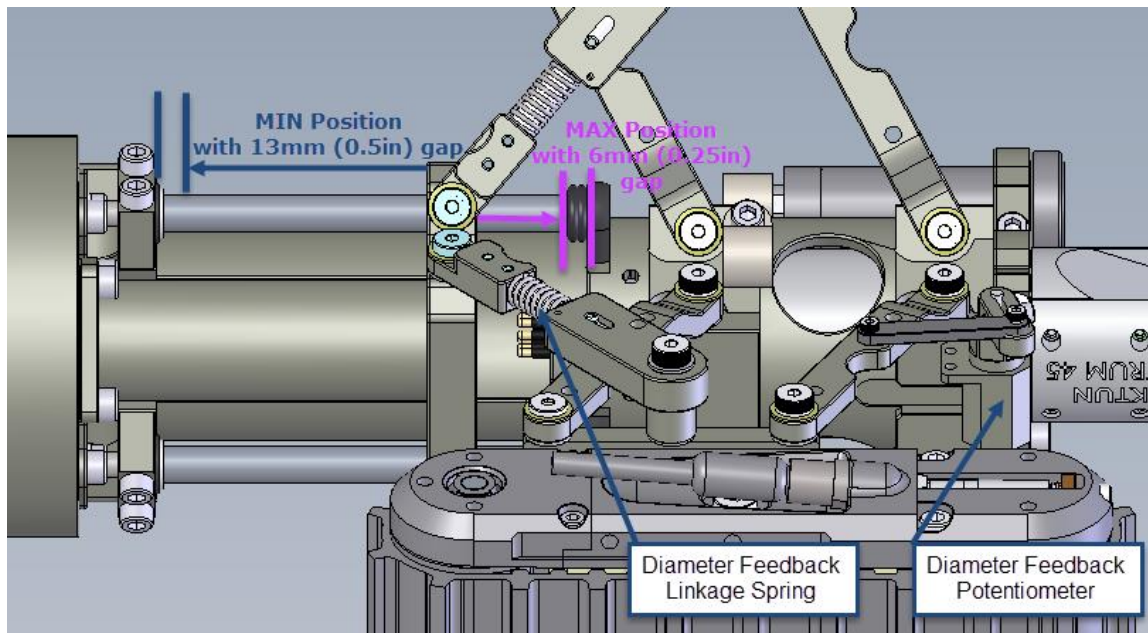

## Force Feedback Calibration

1. Drive the expansion mechanism somewhere in the middle of its travel.
2. With no load on the spring link, Set **MIN** in ICON.
3. Set **MAX**, in ICON when there is no load on the spring link.
4. Push down the linkage and fully **compress the spring**, Set **MAX** in ICON.

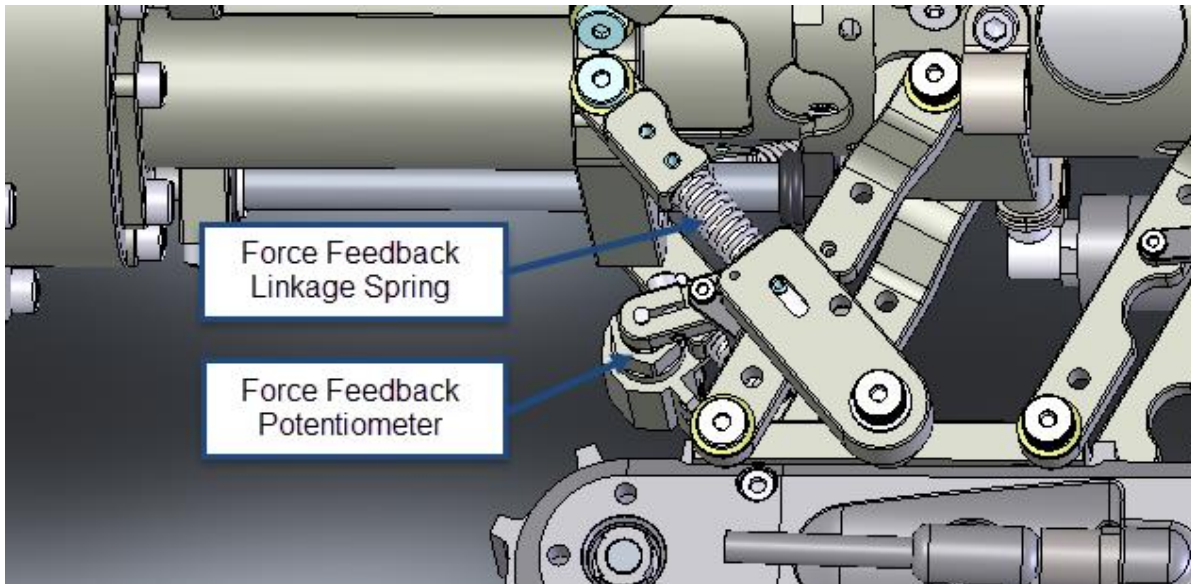

**IMPORTANT:** Always double check your calibration after completion.

Note: Force and diameter feedback are included for operator situational awareness only and are never intended to provide accurate measurements.

**Parts and Repairs****Ordering Parts/Customer Service**

Spare and/or replacement parts are available for your product and can be ordered directly from your local office.

When ordering parts, always make sure to quote the sales order acknowledgement (SOA) number and/or the serial number of the system component in question.

Eddyfi Robotics Inc. (Canadian Headquarters and Manufacturing Location)

2569 Kenworth Road, Suite C

Nanaimo, BC, V9T 3M4

CANADA

TF 1.877.468.5886

T +1.250.729.8080

info@eddyfi.com

www.eddyfitechnologies.com

Eddyfi Technologies – US (American Authorized Distributor and Service Centre)

812 W 13th Street

Deer Park, TX, 77536

USA

T +1.281.542.3292

info@eddyfi.com

www.eddyfitechnologies.com

|  |               |                |                   |                  |
|--|---------------|----------------|-------------------|------------------|
| Document: UMDT017749.docm  | Revision: A02 | Created by: JS | Date: 13 Apr 2021 | IPN: 3094329-A02 |
| Source Location: C:\ePDM\ISLEng\Products\DT-VersaTrax100MkII\Manuals\UMDT017749.docm |               |                |                   | Page 35 of 36    |

## Warranty Repairs

Warranty conditions are specified in the Warranty section. Should any conditions of the manufacturer's warranty be breached, the warranty may be considered void. All returned items must be sent prepaid to Eddyfi Technologies at the above address.

## Factory Returns to Canada

Some sub-assemblies of your Eddyfi Technologies product are not field-serviceable and may need to return to the factory for repair. Warranty claims must return to the factory for evaluation.

To return an item for evaluation or repair, first contact Eddyfi Technologies at our toll-free number or e-mail address. Eddyfi Technologies will supply a Return Merchandise Authorization (RMA) number with detailed shipping and customs instructions. Items shipped without an RMA number will be held at Eddyfi Technologies until the correct paperwork is completed. If cross-border shipments are not labelled as per the instructions, the items may be held by customs and issued additional fees.

All returned items must be sent prepaid unless other specific arrangements have been made.

When the product or system is being shipped anywhere by courier or shipping company, it must be packaged in the original packaging it was received in. This measure greatly reduces the consequences of rough handling and subsequent shipping damage.

Eddyfi Technologies cannot be held responsible for damages due to improper packaging. Shipping damage may have significant impact on repair turnaround times.

## Product/System Drawing Package Availability

Mechanical assembly and electrical wiring diagram drawing packages for your equipment are available in PDF format upon request. Printed copies may also be purchased from Eddyfi. Contact your local sales contact for more information.

## Limited Warranty Policy

Refer the Eddyfi Technologies website for warranty terms for this product.

<https://www.eddyfi.com/en/salesterms>

|  |               |                |                   |                  |
|--|---------------|----------------|-------------------|------------------|
| Document: UMDT017749.docm  | Revision: A02 | Created by: JS | Date: 13 Apr 2021 | IPN: 3094329-A02 |
| Source Location: C:\ePDM\ISLEng\Products\DT-VersaTrax100MkII\Manuals\UMDT017749.docm |               |                |                   | Page 36 of 36    |